

**Coriolis mass flowmeter**

**CMM  
CT**

**Device description**



1.	IDENTIFICATION .....	5
2.	THE CMM SENSOR .....	6
2.1	Application domain of the CMM sensor .....	6
2.2	Mode of operation .....	6
2.2.1	Measuring principle .....	6
2.2.2	System configuration .....	6
2.2.3	Input .....	6
2.3	Custody transfer operations .....	6
2.4	Performance characteristics of the CMM sensor .....	7
2.4.1	Reference conditions .....	7
2.4.2	CMM flow ranges .....	7
2.4.3	Density measurement .....	8
2.4.4	Accuracy .....	8
2.4.5	Pressure loss CMM .....	9
2.4.6	Ambient temperature .....	10
2.4.7	Ambient temperature range .....	10
2.4.8	Storage temperature .....	10
2.4.9	Climatic category .....	10
2.4.10	Ingress protection .....	10
2.5	Operating conditions .....	10
2.5.1	Installation .....	10
2.5.2	Installation positions .....	11
2.5.3	Assessment of installation position .....	12
2.5.4	Pressure surges .....	13
2.5.5	Using the device with hazardous fluids .....	13
2.5.6	Vibration stability .....	13
2.6	Process conditions .....	15
2.6.1	Process temperature .....	15
2.6.2	Physical state .....	15
2.6.3	Viscosity .....	15
2.6.4	Gas content .....	15
2.6.5	Process temperature range .....	15
2.6.6	Process pressure range .....	15
2.6.7	Outlet pressure .....	15
2.7	Connection to the transmitter .....	15
2.7.1	Integral mount configuration .....	15
2.7.2	Remote mount configuration .....	15
2.8	Construction details .....	16
2.8.1	Dimensions and weight .....	16
2.8.2	Dimension drawing for the types CMM-B to CMM-K .....	18
2.8.2.1	Standard version dimension drawing .....	18
2.8.2.2	Integral mount version up to 150 °C (302 °F) .....	18
2.8.2.3	Remote mount version dimension drawing .....	19
2.8.2.4	Remote mount version dimension drawing up to 180 °C (356 °F) .....	19

2.8.2.5	Remote mount version dimension drawing up to 260 °C (500 °F)	19
2.8.3	Heater dimension drawings for CMM-B up to CMM-K	20
2.8.3.1	Standard Heater for integral mount version CMM-B to CMM-K	20
2.8.3.2	Heater for integral mount version up CMM-B to CMM-C	20
2.8.3.3	Heater for remote mount version CMM-D to CMM-K	21
2.8.3.4	Heater for remote mount version up CMM-B to CMM-C	21
2.8.3.5	Heater for remote mount version up to 260 °C (500 °F)	21
2.8.4	Material	22
2.9	Sensor CMM approvals	23
2.9.1	Explosion protection	23
2.9.2	CE marking	23
2.9.3	Custody transfer operations	23
3.	APPLICATION DOMAIN OF THE CT TRANSMITTER	24
4.	CT TRANSMITTER: MODE OF OPERATION AND CONFIGURATION	24
4.1	Measuring principle	24
4.2	System configuration	25
4.2.1	DSB data memory module	25
5.	INPUT	26
5.1	Measured variable	26
5.2	Measuring range	26
6.	OUTPUT	27
6.1	Output signal	27
6.2	Failure signal	27
6.3	Load	28
6.4	Damping	28
6.5	Low flow cutoff	28
7.	CT PERFORMANCE CHARACTERISTICS	28
7.1	Reference conditions	28
7.2	Measured error	28
7.3	Repeatability error	28
7.4	Influence of ambient temperature	28

8.	CT OPERATING CONDITIONS.....	29
8.1	Installation conditions and cable glands.....	29
8.2	Environmental conditions.....	29
8.2.1	Ambient temperature.....	29
8.2.2	Ambient temperature range.....	29
8.2.3	Storage temperature.....	29
8.2.4	Ingress protection.....	29
8.3	Process conditions.....	30
8.3.1	Fluid temperature.....	30
8.3.2	Physical state.....	30
8.3.3	Viscosity.....	30
8.3.4	Fluid temperature limit.....	30
8.3.5	Flow rate limit.....	30
8.3.6	Pressure loss.....	30
9.	CONSTRUCTION DETAILS.....	31
9.1	Type of construction/dimensions.....	31
9.2	Weight.....	32
9.3	Material.....	32
9.4	End connection.....	32
9.5	Electrical connection.....	33
9.5.1	CT connections.....	33
9.5.2	Wiring diagram.....	35
9.5.2.1	Wiring diagram for the integral mount configuration of sensor and CT.....	35
9.5.2.2	Wiring diagram for the remote mount configuration of sensor and CT.....	36
9.5.3	HART®.....	37
9.5.4	Communication via SensorPort.....	37
10.	CONTROL UNIT BE2.....	38
10.1	Introduction.....	38
10.2	Display.....	38
11.	CERTIFICATES AND APPROVALS.....	39
12.	STANDARDS AND AUTHORIZATIONS.....	39
12.1	General standards and directives.....	39
12.2	Electromagnetic compatibility.....	39
12.3	Ex-Approval transmitter.....	39

## 1. Identification

Manufacturer FCI Fluid Components International LLC  
1755 La Costa Meadows Drive  
San Marcos, CA 92078

Phone: 760 – 744 – 6950  
Fax: 760 – 736 – 6250

Internet: <http://www.fluidcomponents.com>  
E-mail: <mailto:techsupport@fluidcomponents.com>

European Office:

Persephonestraat 3-01  
5047 TT Tilburg  
Netherlands

Phone: +31 – 13 – 515 9989  
Fax: +31 – 13 – 579 9036

Product type Mass flowmeter for liquid and gaseous products

Product name Sensor type CMM  
Transmitter type CT, suitable for CMM, CMB and CMU Coriolis mass flow-  
meters

Version no. 1.6, dated April 10, 2006

## 2. The CMM sensor

### 2.1 Application domain of the CMM sensor

The sensor is intended for use solely for direct and continuous mass flow measurement of liquids and gases, irrespective of their conductivity, density, temperature, pressure, or viscosity. The sensor is also intended for use for the direct and continuous mass flow measurement of chemical fluids, suspensions, molasses, paint, varnish, lacquer, pastes and similar materials.

### 2.2 Mode of operation

#### 2.2.1 Measuring principle

The Coriolis mass flowmeter is based on the principle whereby in a rotating system a force (known as the Coriolis force) is exerted on a mass at a rotation point that is moving towards or away from this point.

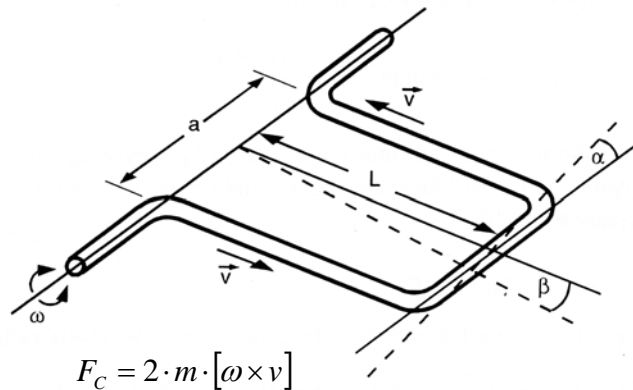

#### 2.2.2 System configuration

The flowmeter consists of a sensor that is mounted in a pipe, and a transmitter (see Section 3 **Application domain of the CT** on pp. 24), that can be directly mounted on the sensor or installed separately (e.g. on a wall).

The transmitter oscillates the flow tubes in the sensor over an excitation coil and picks up, via the sensor coil, the measuring signal which is proportional to the mass flow. After being temperature compensated, the measuring signal is converted into an analog output signal that is consistent with the measuring range setting.

#### 2.2.3 Input

Measured variables: mass flow, density, temperature; volume flow is calculated

## 2.3 Custody transfer operations

Units designated for custody transfer operation may be certified in accordance to the local or national ordinance. Transmitters ordered for custody transfer applications incorporate special tamper-proof software, sealed and certified, that prevents the reset of the internal totalizer.

## 2.4 Performance characteristics of the CMM sensor

### 2.4.1 Reference conditions

- Established flow profile
- Inlet section has to correspond to mounting length
- Operation is to be realized in the presence of downstream control valves
- Measurement is to be realized in the absence of any gas bubbles
- Flow tubes are to be kept clean at all times
- Process temperature is to be regulated as specified in Section 2.6.1 Process temperature on page 15
- Process pressure is to be regulated as specified in Section 2.6.6 Process pressure range on page 15
- Ambient temperature is to range from + 10 °C to + 30 °C (50 °F to 86 °F)
- Warm-up period: 15 minutes
- Standard calibration is to be realized at 20 %, 50 % and 100 % (three times each)
- High-frequency interference is to be regulated as specified in Section 12.2 Electromagnetic compatibility on page 39

### 2.4.2 CMM flow ranges

Model	Min. measuring range	Max. measuring range	Nominal (p=1bar)	Zero point stability (of range)
	kg/h [lbs/min]	kg/h [lbs/min]	kg/h [lbs/min]	kg/h [lbs/min]
CMM-B-S/H	20 [0.7]	200 [7.3]	88 [3.2]	0.02 [0.001]
CMM-C-S/H	35 [1.3]	350 [12.9]	277 [10.2]	0.035 [0.00]
CMM-D-S/H	120 [4.4]	1,200 [44.1]	1,070 [39.3]	0.12 [0.00]
CMM-E-S/H	300 [11.0]	3,000 [110.2]	3,000 [110.2]*	0.3 [0.0]
CMM-F-S/H	600 [22.0]	6,000 [220.5]	6,000 [220.5]	0.6 [0.0]
CMM-G-S/H	2,000 [73.5]	20,000 [734.9]	15,000 [551.1]	2 [0.1]
CMM-J-S	4,000 [147.0]	40,000 [1,469.7]	37,000 [1,359.5]	4 [0.1]
CMM-J-H	4,000 [147.0]	35,000 [1,286.0]	29,000 [1,065.5]	3.5 [0.1]

\* (p=0,5bar)

CMM-C-T	4 [0.1]	40 [1.5]	350 [12.9]	325 [11.94]
CMM-D-T	6 [0.2]	120 [4.4]	1,200 [44.1]	1060 [38.95]
CMM-E-T	26 [1.0]	400 [14.7]	3,000 [110.2]*	3000 [110.2]
CMM-F-T	46 [1.7]	700 [25.7]	6,000 [220.5]	4850 [178.2]
CMM-G-T	150 [5.5]	2,000 [73.5]	18,000 [661.4]	13500 [496.0]
CMM-J-T	200 [7.3]	4,000 [147.0]	30,000 [1,102.3]	30000 [1102.3]
CMM-K-T	300 [11.0]	6,000 [220.5]	65,000 [2,388.3]**	65000 [2388.3]

\* (p=0,57bar)

\*\* (p=0,68bar)

Reference conditions: in conformity with IEC 770:  
 Temperature: 20 °C, relative humidity: 65 %, air pressure: 101.3 kPa  
 Fluid: water

**2.4.3 Density measurement**

The attainable accuracy depends on the selected calibration type.



**Without calibration no density measurement is possible and the empty pipe recognition is not available!**

Model	Density accuracy		
	without	3-Point	5-Point
CMM-B	no measurement of density	not available	
CMM-C		not available	
CMM-D		5 g/l	3 g/l
CMM-E		5 g/l	3 g/l
CMM-F		5 g/l	3 g/l
CMM-G		5 g/l	3 g/l
CMM-J		5 g/l	3 g/l
CMM-K		5 g/l	3 g/l

**2.4.4 Accuracy**

<b>Mass flow</b>	
Accuracy CMM-B to CMM-K	± 0.1% of actual flow + zero point stability (see Section 2.4.2 CMM flow ranges) ± 0.005% of actual flow + zero point stability with special calibration (see Section 2.4.2 CMM flow ranges)
Repeatability error	± 0.05% of actual flow (sensor with transmitter)
<b>Additional measured values</b>	
Volume flow	± 0.2 % of actual value + zero point stability
Temperature	± 0.5 °C
Hysteresis	n/a
Settling time	1 to 15 seconds
Startup drift	15 minutes
Long-term drift	± 0.02 % of upper-range value per year
Influence of ambient temperature	± 0.005 % per K
Influence of fluid temperature	Compensated
Influence of fluid pressure	For fluids: too small to be relevant



### 2.4.5 Pressure loss CMM

Model	Min. measuring range	Max. measuring range	Pressure loss [water (20°C), 1 mPas]				
			20 kg/h	50 kg/h	100 kg/h	150 kg/h	200 kg/h
CMM-B-S/H	20 kg/h	200 kg/h	0.07 bar	0.36 bar	1.22 bar	2.48 bar	4.11 bar
			20 kg/h	50 kg/h	100 kg/h	150 kg/h	200 kg/h
CMM-C-S/H	35 kg/h	350 kg/h	0.03 bar	0.21 bar	0.53 bar	0.97 bar	1.51 bar
			35 kg/h	113.75 kg/h	192.5 kg/h	271.25 kg/h	350 kg/h
CMM-D-S/H	120 kg/h	1200 kg/h	0.02 bar	0.17 bar	0.43 bar	0.79 bar	1.23 bar
			120 kg/h	390 kg/h	660 kg/h	930 kg/h	1200 kg/h
CMM-E-S/H	300 kg/h	3000 kg/h	0.01 bar	0.06 bar	0.16 bar	0.29 bar	0.45 bar
			300 kg/h	975 kg/h	1650 kg/h	2325 kg/h	3000 kg/h
CMM-F-S/H	600 kg/h	6000 kg/h	0.02 bar	0.13 bar	0.33 bar	0.61 bar	0.95 bar
			600 kg/h	1950 kg/h	3300 kg/h	4650 kg/h	6000 kg/h
CMM-G-S/H	2000 kg/h	20000 kg/h	0.03 bar	0.23 bar	0.58 bar	1.05 bar	1.64 bar
			2000 kg/h	6500 kg/h	11000 kg/h	15500 kg/h	20000 kg/h
CMM-J-S	4000 kg/h	40000 kg/h	0.02 bar	0.16 bar	0.41 bar	0.75 bar	1.17 bar
			4000 kg/h	13000 kg/h	22000 kg/h	31000 kg/h	40000 kg/h

CMM-J-H	4,000 kg/h	40,000 kg/h	0.03 bar	0.25 bar	0.62 bar	1.13 bar	1.77 bar
			4,000 kg/h	13,000 kg/h	22,000 kg/h	31,000 kg/h	40,000 kg/h

CMM-C-T	40 kg/h	350 kg/h	0.03 bar	0.17 bar	0.40 bar	0.72 bar	1.12 bar
			40 kg/h	118 kg/h	195 kg/h	273 kg/h	350 kg/h
CMM-D-T	120 kg/h	1,200 kg/h	0.02 bar	0.17 bar	0.43 bar	0.79 bar	1.23 bar
			120 kg/h	390 kg/h	660 kg/h	930 kg/h	1,200 kg/h
CMM-E-T	400 kg/h	3,000 kg/h	0.02 bar	0.09 bar	0.21 bar	0.37 bar	0.57 bar
			400 kg/h	1,050 kg/h	1,700 kg/h	2,350 kg/h	3,000 kg/h
CMM-F-T	700 kg/h	6,000 kg/h	0.03 bar	0.21 bar	0.51 bar	0.91 bar	1.41 bar
			700 kg/h	2,025 kg/h	3,350 kg/h	4,675 kg/h	6,000 kg/h
CMM-G-T	2,000 kg/h	18,000 kg/h	0.04 bar	0.24 bar	0.59 bar	1.07 bar	1.66 bar
			2,000 kg/h	6,000 kg/h	10,000 kg/h	14,000 kg/h	18,000 kg/h
CMM-J-T	4,000 kg/h	30,000 kg/h	0.03 bar	0.15 bar	0.36 bar	0.63 bar	0.97 bar
			4,000 kg/h	10,500 kg/h	17,000 kg/h	23,500 kg/h	30,000 kg/h
CMM-K-T	6,000 kg/h	65,000 kg/h	0.01 bar	0.09 bar	0.23 bar	0.43 bar	0.67 bar
			6,000 kg/h	20,750 kg/h	35,500 kg/h	50,250 kg/h	65,000 kg/h

Model	Min. measuring range	Max. measuring range	Pressure loss [water (20°C), 1 mPas]				
			0.7 lbs/min	1.8 lbs/min	3.7 lbs/min	5.5 lbs/min	7.3 lbs/min
CMM-B-S/H	0.7 lbs/min	7.3 lbs/min	1.06 psi	5.27 psi	17.71 psi	36.01 psi	59.57 psi
			0.7 lbs/min	1.8 lbs/min	3.7 lbs/min	5.5 lbs/min	7.3 lbs/min
CMM-C-S/H	1.3 lbs/min	12.9 lbs/min	0.39 psi	3.06 psi	7.70 psi	14.02 psi	21.91 psi
			1.3 lbs/min	4.2 lbs/min	7.1 lbs/min	10.0 lbs/min	12.9 lbs/min
CMM-D-S/H	4.4 lbs/min	44.1 lbs/min	0.32 psi	2.50 psi	6.27 psi	11.43 psi	17.85 psi
			4.4 lbs/min	14.3 lbs/min	24.3 lbs/min	34.2 lbs/min	44.1 lbs/min
CMM-E-S/H	11.0 lbs/min	110.2 lbs/min	0.12 psi	0.92 psi	2.30 psi	4.20 psi	6.56 psi
			11.0 lbs/min	35.8 lbs/min	60.6 lbs/min	85.4 lbs/min	110.2 lbs/min
CMM-F-S/H	22.0 lbs/min	220.5 lbs/min	0.24 psi	1.92 psi	4.83 psi	8.80 psi	13.74 psi
			22.0 lbs/min	71.6 lbs/min	121.3 lbs/min	170.9 lbs/min	220.5 lbs/min
CMM-G-S/H	73.5 lbs/min	734.9 lbs/min	0.42 psi	3.33 psi	8.37 psi	15.25 psi	23.83 psi
			73.5 lbs/min	238.8 lbs/min	404.2 lbs/min	569.5 lbs/min	734.9 lbs/min
CMM-L-S	147.0 lbs/min	1469.7 lbs/min	147.0 lbs/min	477.7 lbs/min	808.3 lbs/min	1139.0 lbs/min	1469.7 lbs/min

**2.4.6 Ambient temperature**

- 40 °C to + 60 °C (-40 °F to 140 °F)

**2.4.7 Ambient temperature range**

- 40 °C to + 60 °C (-40 °F to 140 °F); a special cable is required for temperatures below - 20 °C (-4 °F)

**2.4.8 Storage temperature**

- 25 °C to + 60 °C (-13 °F to 140 °F), - 40 °C (-40°F) available as special version

**2.4.9 Climatic category**

In conformity with IEC 654-1. Unsheltered class D locations with direct open-air climate.

**2.4.10 Ingress protection**

Standard version: IP 66 (NEMA 6); special version IP 68 (NEMA 6P) DIN EN 60529, if suitable and tightly screwed down cable glands are used.

**2.5 Operating conditions**

**2.5.1 Installation**

The sensor is to be protected, wherever possible, against valves, manifolds and similar fittings that generate turbulence. The sensor is to be installed in accordance with the following instructions.

Diagram showing flowmeter installation

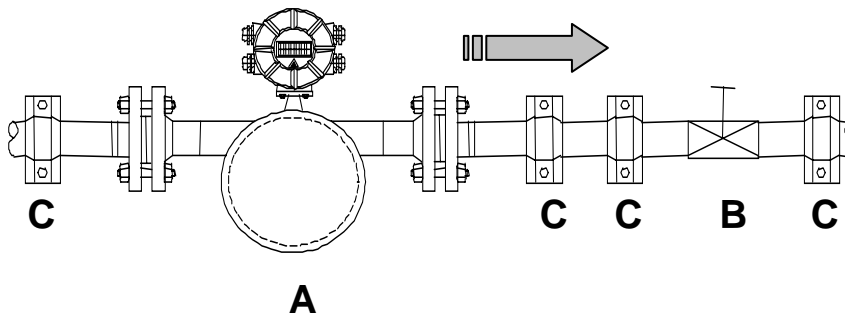

Flowmeter installation: A = sensor, B = valve, C = pipe clamps and supports



Under no circumstances is the sensor to be used to support a pipe.

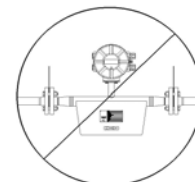



Do not install the sensor in suspended pipes.

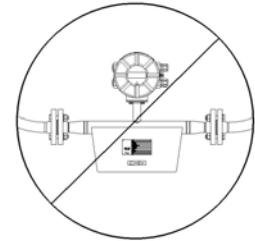

Do not adjust the position of a pipe by pulling or grasping the sensor.

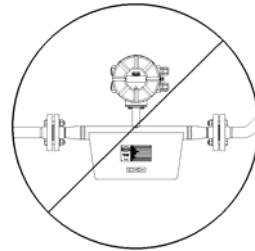

### 2.5.2 Installation positions

<p>Standard installation position</p>	
<p>Installation position A</p>	
<p>Installation position B</p>	

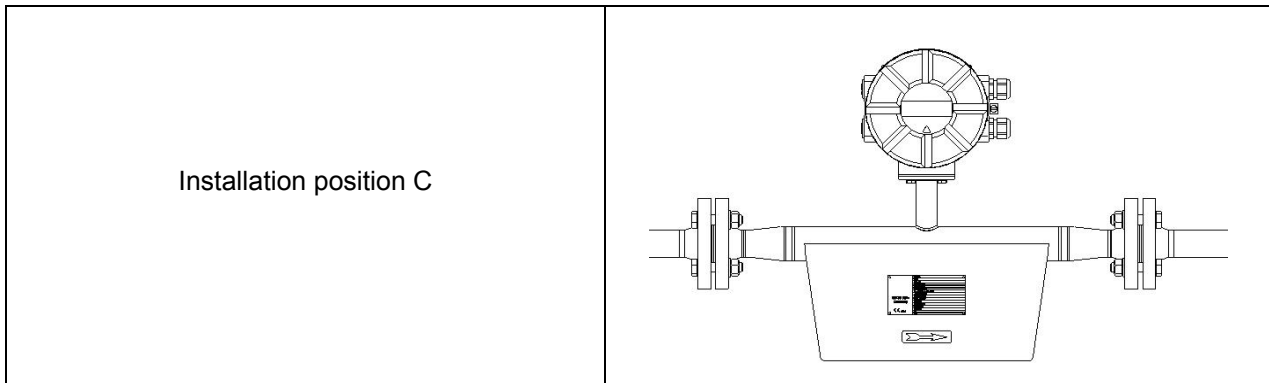

### 2.5.3 Assessment of installation position

Type of fluid	Position	Assessment
Pure liquids	Standard installation position	Self-draining flow tubes
	Position A or B	OK
	Position C	Liquid residue remains in pipe
Liquids with gas bubbles	Standard installation position	Self-draining flow tubes, gas bubbles do not accumulate in flowmeter
	Position A	Not recommended owing to gas bubble accumulation in flowmeter
	Position B	Gas bubbles may accumulate in the presence of low flow velocities
	Position C	No gas bubble accumulation in flowmeter, liquid residues may remain in device after discharge
Liquids containing substances that could form deposits	Standard installation position	Self-draining flow tubes, no deposit formation
	Position A	OK
	Position B	Substances in the liquid could form deposits at low flow velocities
	Position C	Not recommended owing to presence in flowmeter of substances that could form deposits
Liquids containing gas bubbles, as well as gas bubbles containing substances that could form deposits	Standard installation position	Self-draining flow tubes, no accumulation of gases or substances that could form deposits
	Position A	Not recommended owing to gas bubble accumulation in flowmeter
	Position B	Gas bubbles or substances that could form deposits at low flow velocities
	Position C	Not recommended owing to presence in flowmeter of substances that could form deposits
Gases that do not form a condensate	Standard installation position, Position A, B or C	Any of these installations positions can be used

Type of fluid	Position	Assessment
Gas, condensate-forming gas/liquid, moisture	Standard installation position	Flow direction should be from top to bottom so that any condensate that forms can flow out efficiently
	Position A	OK
	Position B	Condensate might form in flowmeter
	Position C	Not recommended owing to condensate accumulation in flowmeter
Slurries	Standard installation position	Optimal installation position
	Position A	High density substances could accumulate in the flowmeter
	Position B	Gas bubbles could accumulate
	Position C	Gas bubbles or high density substances could accumulate in the flowmeter

#### 2.5.4 Pressure surges

Pressure surges in a pipe could be provoked by a sudden decrease in flow caused by rapid closing of a valve or similar factors. This change in pressure can lead to underpressure downstream from a valve that has been closed rapidly, and to outgasing. If the valve is mounted directly on the inlet section of the flowmeter, a gas bubble can form in the flow tube that can cause a measuring signal disturbance that would shift the zero point of the output signal. In extreme cases, a pressure surge could cause mechanical damage to the sensors and/or flow tube.

Whenever possible, quick-closing valves should be mounted downstream from the sensor. If this is not feasible, such valves are to be mounted a minimum of 10 x DIA ( $\Phi$ ) from the nearest sensor. Alternatively, valve closing speed can be reduced.

#### 2.5.5 Using the device with hazardous fluids

The sealing technology used in the standard mass flowmeter renders the device unsuitable for use with hazardous fluids. Only sensors that meet the standards for safety instruments are suitable for use with hazardous fluids.

The pathway between the sensor and transmitter must be pressure-tight so as to prevent fluid from leaking out of a sensor in the event a sensor develops a defect.

In the case of welded components, a colored liquid penetration test should be performed on the welds, or one joint (only the first one) should be x-rayed. Alternatively, an internal pressure monitoring device can be used to detect any defect.

#### 2.5.6 Vibration stability

The sensors are insensitive to vibration; vibration stability has been validated in accordance with DIN IEC 68-2-6, for up to 1 g at 10 to 150 Hz.

If pipe vibration is greater than 1 g in the 10-150 Hz range, an additional fastening is to be mounted as shown in the following drawings. This fastening will prevent vibration from affecting the device's mechanical configuration and/or measurement readings. The following drawings are valid for a sensor with a nominal size of approximately 2 inch [DN 040]. Installation is to be realized as shown in this drawing.

Installation using wall supports

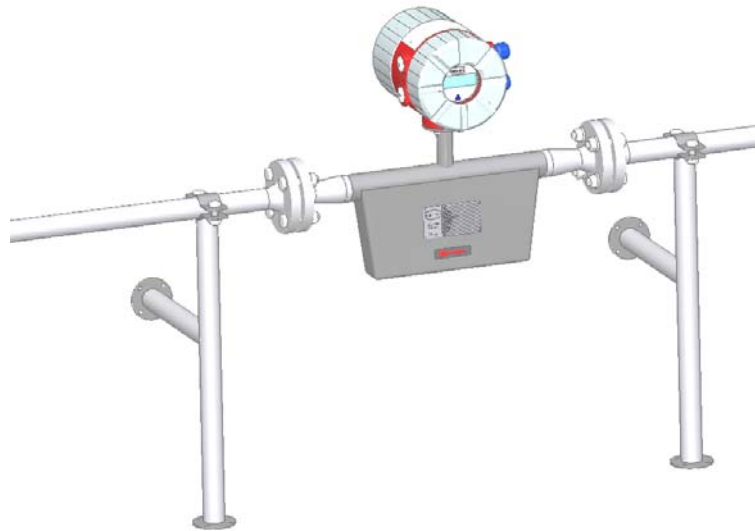

Foot-mounted installation

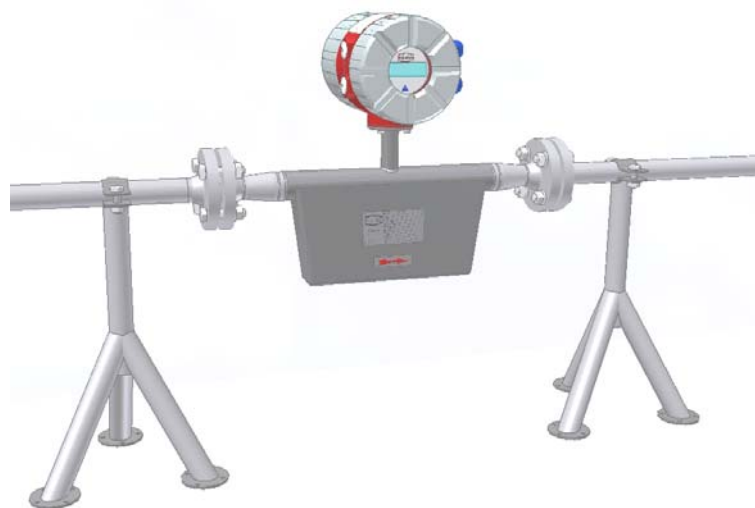

## 2.6 Process conditions

### 2.6.1 Process temperature

– 90 °C to + 260 °C (–130 °F to 500 °F); rating plate range must be observed

### 2.6.2 Physical state

Liquid product (maximum density 2 kg/l)  
Gaseous product (minimum density 0.002 kg/l in operating state)

### 2.6.3 Viscosity

0.3 up to 50,000 mPas (0.3 to 50,000 cP)

### 2.6.4 Gas content

The use of products containing gas is not allowed for custody transfer operations. In other applications, the presence of gas will increase false readings. In order for the readings of products containing gas to be valid, small gas bubbles must be homogeneously distributed in the fluid. Large gas bubbles will automatically provoke extremely false readings and will shift the zero point. Thus, the extent to which readings are false is determined by the process conditions. A rule of thumb in this regard is as follows: A 1 % gas component will increase false readings by 1 %. The gas component is not to exceed 5 %.

### 2.6.5 Process temperature range

+ 260 °C (500 °F)

### 2.6.6 Process pressure range

According to PN16 pressure rating: 232 psig [16 bar] and PN40: 580 psig [40 bar]  
Considerably higher pressure range possible depending on materials and tube selection selected at time of order. Do not exceed rating noted on name plate.

### 2.6.7 Outlet pressure

Outlet pressure must be greater than the vapor pressure  $P_s$  (static pressure) of the measured product.

## 2.7 Connection to the transmitter

### 2.7.1 Integral mount configuration

When the transmitter is mounted directly on the sensor, no cable connection between the two components is needed. This connection is integrated at the factory.

### 2.7.2 Remote mount configuration

If the transmitter is not mounted directly on the sensor, installation regulations and applicable legal standards are to be adhered to. The maximum cable length is 300 m (1000ft). See Section 9.5.2 Wiring diagram on page 35 for information regarding the connection and cable specifications.

## 2.8 Construction details

### 2.8.1 Dimensions and weight

Standard versions:

Model	End connection		End connection		End connection		A End connection	
	mm [inch]	mm [inch]	mm [inch]	mm [inch]	mm [inch]	mm [inch]	mm [inch]	mm [inch]
CMM-B	SW10	350 [13.8]	SW12	350 [13.8]	DN10 PN40	350 [13.8]	1/4" NPT (f)	350 [13.8]
CMM-C	SW12	350 [13.8]	DN10 PN40	350 [13.8]	DN15 PN40	350 [13.8]	1/4" NPT (f)	350 [13.8]
CMM-D	DN10 PN40	400 [15.7]	DN15 PN40	400 [15.7]	DN25 PN40	400 [15.7]	1/2" NPT (f)	400 [15.7]
CMM-E	-	-	DN15 PN40	450 [17.7]	DN25 PN40	450 [17.7]	1/2" NPT (f)	450 [17.7]
CMM-F	DN15 PN40	550 [21.7]	DN25 PN40	550 [21.7]	DN50 PN40	550 [21.7]	ANSI 1/2" 150/600lb 3/4" NPT (f)	550 [21.7] 550 [21.7]
CMM-G	-	-	DN25 PN40	650 [25.6]	DN50 PN40	650 [25.6]	ANSI 3/4" 150/600lb 3/4" NPT (f)	650 [25.6] 650 [25.6]
CMM-J	DN50 PN40	750 [29.5]	DN80 PN40	750 [29.5]	DN100 PN40	750 [29.5]	ANSI 1 1/2" 150/600lb	750 [29.5]
CMM-K	DN80 PN40	750 [29.5]	-	-	-	-	ANSI 3" 150lb	750 [29.5]

Model	B					C	F	G
	Integrated Mount Transmitter		Remote Mount Transmitter					
	-40°C - 100°C (-40°F to 212°F)	-40°C - 150°C (-40°F to 302°F)	-40°C - 100°C (-40°F to 212°F)	-40°C - 180°C (-40°F to 356°F)	-40°C - 260°C (-40°F to 500°F)			
mm [inch]	mm [inch]	mm [inch]	mm [inch]	mm [inch]	mm [inch]	mm [inch]	mm [inch]	
CMM-B	429 [16.9]	531 [20.9]	331 [13.0]	433 [17.0]	533 [21.0]	125 [4.9]	42 [1.7]	94 [3.7]
CMM-C	429 [16.9]	531 [20.9]	331 [13.0]	433 [17.0]	533 [21.0]	125 [4.9]	42 [1.7]	94 [3.7]
CMM-D	482 [19.0]	584 [23.0]	384 [15.1]	486 [19.1]	586 [23.1]	170 [6.7]	45 [1.8]	112 [4.4]
CMM-E	534 [21.0]	636 [25.0]	436 [17.2]	538 [21.2]	638 [25.1]	215 [8.5]	52 [2.0]	132 [5.2]
CMM-F	534 [21.0]	636 [25.0]	436 [17.2]	538 [21.2]	638 [25.1]	215 [8.5]	52 [2.0]	132 [5.2]
CMM-G	584 [23.0]	686 [27.0]	486 [19.1]	588 [23.1]	688 [27.1]	255 [10.0]	62 [2.4]	162 [6.4]
CMM-J	699 [27.5]	801 [31.5]	601 [23.7]	703 [27.7]	803 [31.6]	378 [14.9]	102 [4.0]	272 [10.7]
CMM-K	629 [24.8]	731 [28.8]	531 [20.9]	633 [24.9]	733 [28.9]	380 [15.0]	115 [4.5]	230 [9.1]



Weight:

Model	DN	Weight	
		Sensor	Transmitter
		kg [lbs]	kg [lbs]
CMM-B	10	5 [11.0]	4.5 [9.9]
CMM-C	10	5 [11.0]	
CMM-D	15	12 [26.5]	
CMM-E	25	15 [33.1]	
CMM-F	25	15 [33.1]	
CMM-G	50	24 [52.9]	
CMM-J	80	40 [88.2]	
CMM-K	100	110 [242.5]	

Heated versions:

Model	K	L	M
	inch [mm]	inch [mm]	inch [mm]
CMM-B	4.6 [116]	5.6 [142]	3.7 [93.5]
CMM-C	4.6 [116]	5.6 [142]	3.7 [93.5]
CMM-D	5.9 [150]	7.3 [185]	4.2 [107]
CMM-E	7.1 [180]	8.9 [227]	4.7 [120]
CMM-F	7.1 [180]	8.9 [227]	4.7 [120]
CMM-G	7.9 [200]	10.3 [262]	5.5 [140]
CMM-J	11.0 [280]	13.5 [343]	8.7 [220]

## 2.8.2 Dimension drawing for the types CMM-B to CMM-K

### 2.8.2.1 Standard version dimension drawing

Integral mount configuration that is suitable for process temperatures up to 100 °C (212°F):

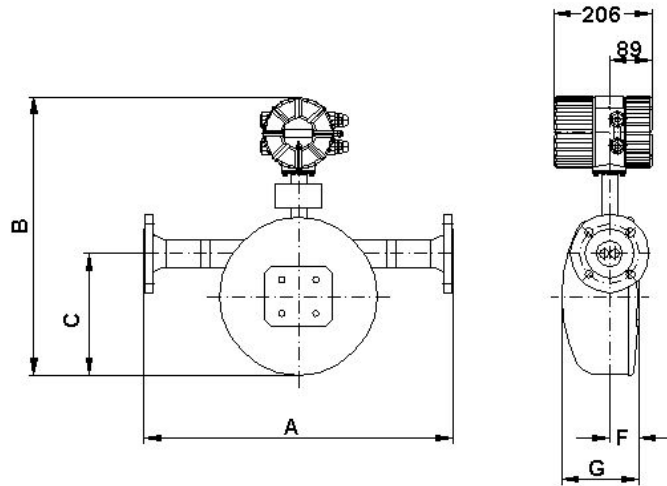

For all the dimensions and weight, see Section 2.8.1 Dimensions and weight on page 16.

### 2.8.2.2 Integral mount version up to 150 °C (302 °F)

Integral mount configuration that is suitable for process temperatures up to 150 °C (302°F):

For all the dimensions and weights, see Section 2.8.1 Dimensions and weight on page 16.

**2.8.2.3 Remote mount version dimension drawing**

Remote mount configuration with junction box that is suitable for process temperatures up to 100 °C (212 °F):

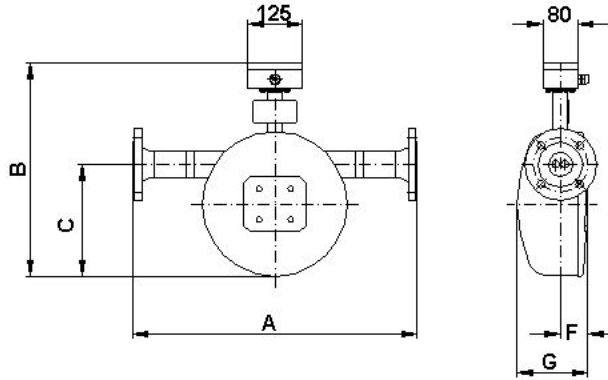

For all the dimensions and weights, see Section 2.8.1 Dimensions and weight on page 16.

**2.8.2.4 Remote mount version dimension drawing up to 180 °C (356 °F)**

Remote mount configuration with junction box that is suitable for process temperatures up to 180 °C (356 °F):

For all the dimensions and weights, see Section 2.8.1 Dimensions and weight on page 16.

**2.8.2.5 Remote mount version dimension drawing up to 260 °C (500 °F)**

Remote mount configuration with junction box that is suitable for process temperatures up to 260 °C (500 °F):

For all the dimensions and weights, see Section 2.8.1 Dimensions and weight on page 16.

**2.8.3 Heater dimension drawings for CMM-B up to CMM-K**

**2.8.3.1 Standard Heater for integral mount version CMM-B to CMM-K**

Integral mount configuration that is suitable for process temperatures up to 100 °C (212 °F):

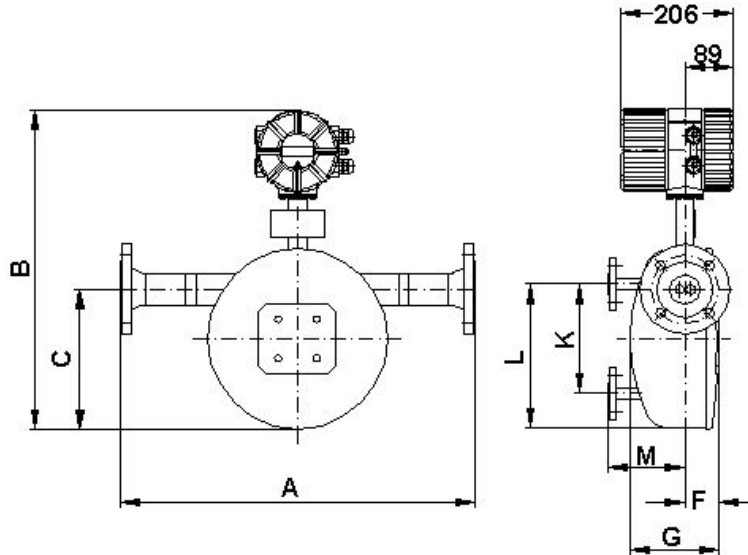

For all the dimensions and weights, see Section 2.8.1 Dimensions and weight on page 16.

**2.8.3.2 Heater for integral mount version up CMM-B to CMM-C**

Integral mount configuration that is suitable for process temperatures up to 100 °C (212 °F):

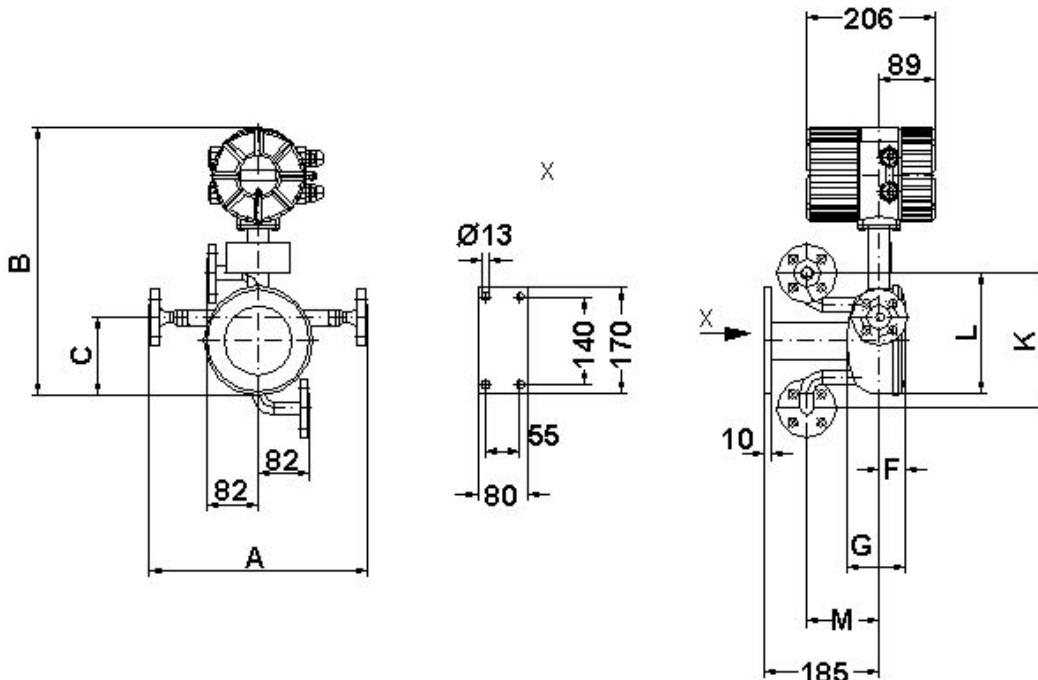

For the dimensions and weights, see Section 2.8.1 Dimensions and weight on page 16.

**2.8.3.3 Heater for remote mount version CMM-D to CMM-K**

Remote mount configuration (with junction box) that is suitable for process temperatures up to 100 °C (212 °F):

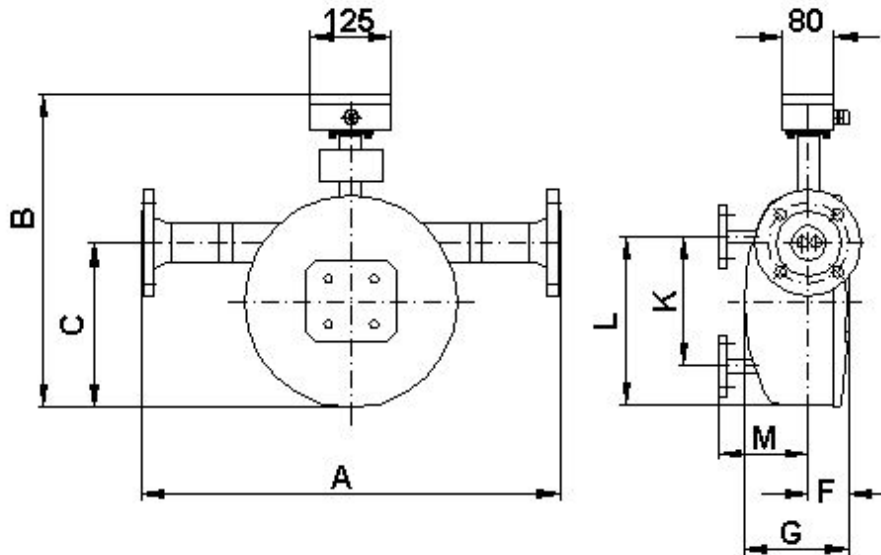

For the dimensions and weights, see Section 2.8.1 Dimensions and weight on page 16.

**2.8.3.4 Heater for remote mount version up CMM-B to CMM-C**

Remote mount configuration (with junction box) that is suitable for process temperatures up to 100 °C (212 °F):

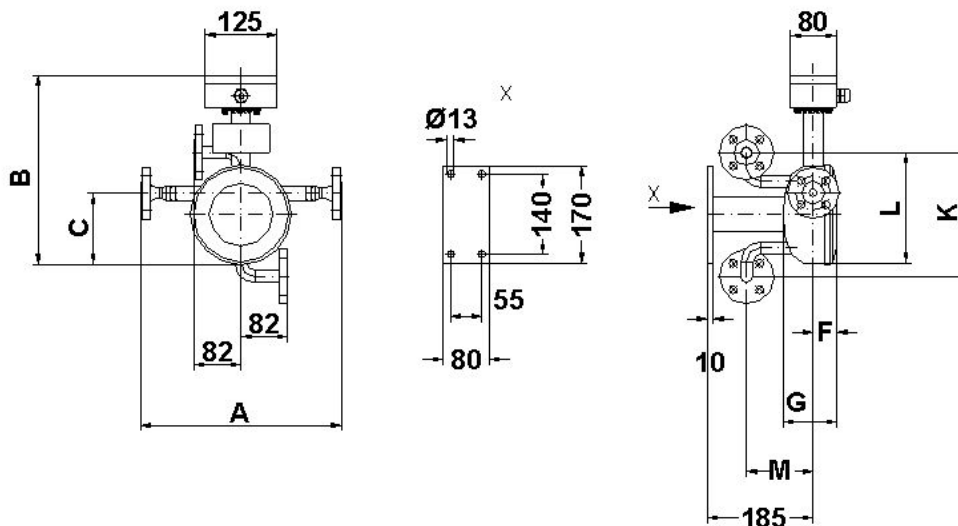

For the dimensions and weights, see Section 2.8.1 Dimensions and weight on page 16.

**2.8.3.5 Heater for remote mount version up to 260 °C (500 °F)**

Remote mount configuration (with junction box) that is suitable for process temperatures up to 260 °C (500 °F):

For the dimensions and weights, see Section 2.8.1 Dimensions and weight on page 16.

#### 2.8.4 Material

Sensor housing	
CMM up to 1 inch [DN025]:	Stainless steel 1.4301 (304L) and aluminum cover Option: stainless steel cover 1.40301
CMM starting from 2 inch [DN050]:	epoxy painted carbon steel, 1.4301 (304L) is available as an option
Flow tubes:	1.4404 (316L)
Splitter:	1.4571 (316Ti)
Sealing strip and/or flange:	Hastelloy Tantalum Other materials on request

## 2.9 Sensor CMM approvals

### 2.9.1 Explosion protection

- Intrinsically safe sensor circuits
- BVS 05 ATEX E 145 X
- II 1/2G EEx ia IIC T6 – T2
- (Zone 0 permissible in flow tube)

The explosion protection approvals are available upon request from the FCI factory.

### 2.9.2 CE marking

- Pressure Equipment Directive 97/23/EC
- Explosion Protection Directive 94/9/EC

### 2.9.3 Custody transfer operations

The declarations of conformity certifying flowmeters for custody transfer operations are available from the FCI factory.

### **3. Application domain of the CT transmitter**

The microprocessor controlled CT transmitter (referred to as CT) for use with CMM, CMB and CMU sensors is a programmable transmitter that processes measurement data and displays and transmits various types of measurement results.

The CT is communication enabled and supports both the HART<sup>®</sup> protocol and Profibus-PA. The device can be customized using control unit BE2. Although basic configuration settings such as transmitter calibration are realized at the factory, other settings such as those for measurement data processing, analysis, display and output are user definable.

User settings are protected by a user definable password.

Settings that are essential for proper operation of the transmitter in conjunction with the sensor (e.g. calibration and initialization values) are accessible only to service technicians via a password that is not provided to customers.

### **4. CT transmitter: mode of operation and configuration**

#### **4.1 Measuring principle**

The Coriolis mass flowmeter is based on the principle whereby in a rotating system a force (known as Coriolis force) is exerted on a mass at a rotation point that is moving towards or away from this point. By configuring the sensor in a specific fashion, this force can be used to measure mass flow directly. The CT transmitter evaluates the sensor signal (see Section 2.2.1 Measuring principle on page 6).



## 4.2 System configuration

### Transmitter:

The CT transmitter regulates the excitation of the sensor vibration system and processes the sensor signals. The standard model is equipped with two analog 0/4 to 20 mA outputs, an impulse or frequency output and a status output, and is enabled for digital data transfer via the HART® protocol. The device is also available with a Profibus-PA field bus.

### Sensor:

The CMM, CMB and CMU sensors measure flow, density and temperature in fluids. The device can be used to perform measurements with any liquid or gaseous product providing that the sensor material is suitable for the product being used.

### 4.2.1 DSB data memory module

The replaceable plug and play memory module is mounted on a printed board and stores all sensor data such as sensor constants, model numbers, serial numbers, and so on. Consequently, the memory module is linked to the sensor and is attached to the transmitter housing with a nylon cord.

If the transmitter is replaced, the memory module should be transferred to the new transmitter. When the flowmeter is started up, the device continues using the values stored in the memory module. Thus, the DSB memory module provides maximum safety and comfort when device components are replaced.

Electronics compartment, CPU board UMC3-30

**DSB slot**

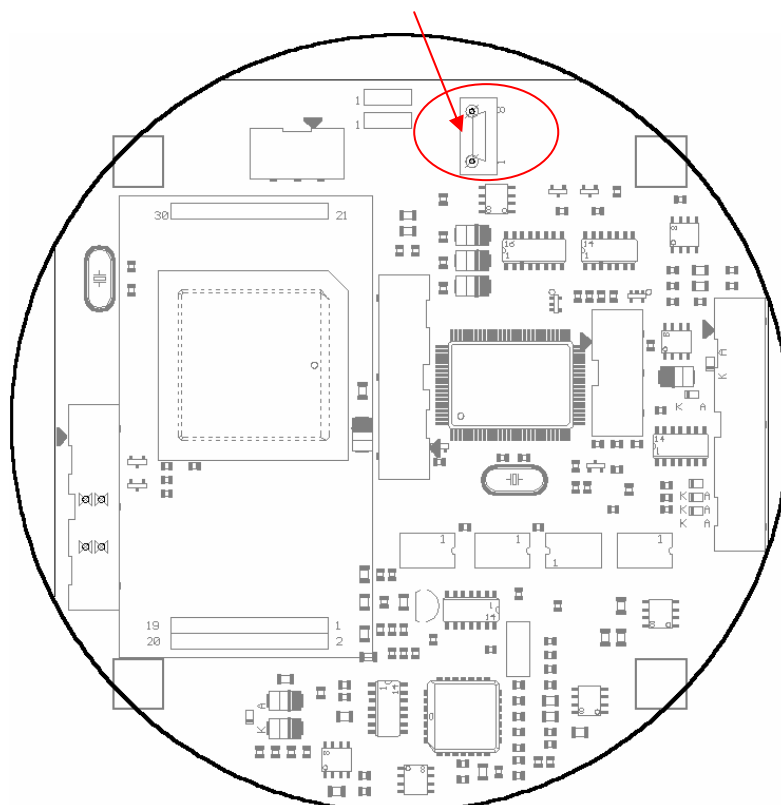

## **5. Input**

### **5.1 Measured variable**

Mass flow rate, temperature, density and volume flow (calculated from the preceding measured variables).

### **5.2 Measuring range**

The measuring range, which varies according to which sensor (CMM, CMB or CMU) is used, can be found on the relevant data sheet or rating plate (see Section 2.4.2 CMM flow ranges on page 7).

## 6. Output

### 6.1 Output signal

All signal outputs

Electrically isolated from each other and from ground

Analog outputs

2 x 0/4 to 20 mA active( EEx “i” [outputs i.s.] or EEx “e”)

Current output 1:

Mass flow, volume flow, density, temperature  
(when using the HART<sup>®</sup> protocol, output 1 is assigned to mass flow)

Current output 2:

Mass flow, volume flow, density, temperature

Pulse output  
(Binary output 1)

Pulse duration: default value 50 ms

Pulse duration: adjustable range is 10 to 2000 ms

Mark-to-space ratio is 1:1 if the set pulse duration is not reached.

As a frequency output 1 kHz (optionally 10 kHz)

Passive, via optocoupler $U_i = 30\text{ V}$ $I_i = 200\text{ mA}$ $P_i = 3\text{ W}$	Active, potential-free (24 V =; max. 20 mA)
--	--

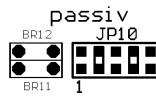
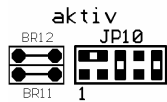

The CT binary output 1 can be wired as a passive or an active output by inserting the JP10 plug-in jumpers on the UMC3-10 PCB accordingly. For the active output, the jumpers BR11 and BR12 must be closed in addition.

Pulse value

1 pulse/unit

The pulse value can be multiplied by a factor between 0.01 and 100.0 (decade increments) of the selected pulse unit, e.g. lbs, kg, m<sup>3</sup>...

Status output

For: forward and reverse flow, MIN flow rate, MAX flow rate (Binary output 2): MIN density, MAX density, MIN temperature, MAX temperature, alarm

Second pulse output (out of phase by 90°)

Passive via optocoupler

$U_i = 30\text{ V}$

$I_i = 200\text{ mA}$

$P_i = 3\text{ W}$

### 6.2 Failure signal

A failure in the meter can be indicated via the current outputs or the status output. The current outputs can be set to a failure signal (alarm) of  $I < 3.8\text{ mA}$  or  $I > 22\text{ mA}$ . The status output can be configured as make or brake contact.

### 6.3 Load

Standard version:	≤ 500 ohms
Explosion-proof version:	≤ 500 ohms
HART® minimum load:	> 250 ohms

### 6.4 Damping

Programmable from 0 to 60 seconds

### 6.5 Low flow cutoff

The low flow cutoff can be set to values between 0 and 20% using the software. The set value refers to the upper-range value. If the measured value is lower than the set volume, the flow rate will set to 0.0 (lb/m, kg/h). This results in the analog output being set to 0/4 mA, and the pulse output will stop generating pulses.

## 7. CT performance characteristics

### 7.1 Reference conditions

In conformity with IEC 770

Temperature: 20 °C (68 °F), relative humidity: 65 %, air pressure: 101.3 kPa (14.7 psi)

### 7.2 Measured error

Measured error and zero point stability see sensor data sheet or Section 2.4.2 CMM flow ranges on page 7.

### 7.3 Repeatability error

± 0.05 % of actual value (sensor with transmitter)

### 7.4 Influence of ambient temperature

± 0.05 % per 10 K

## 8. CT operating conditions

### 8.1 Installation conditions and cable glands

The integral mount version of the CT transmitter in the SG1 housing is to be installed in accordance with Section 2.5.1 Installation on page 10. If the CT transmitter is installed separately, a vibration-free installation site must be ensured.

	<p><b>Warning:</b> Additional cable glands: They are not contained in the scope of supply. The operator is responsible for the fact that according to the enclosure and ignition enclosure certified cable glands or screws are used. The kind of the thread is stamped on the rating plate. At the connection between sensor and transmitter a metalized cable gland must be used for the screen. (See 9.5.2.2 "Wiring diagram for the remote mount configuration of sensor and CT" page 36)</p>
---	---

### 8.2 Environmental conditions

#### 8.2.1 Ambient temperature

- 20 °C to + 60 °C (-4 °F to 140 °F), below 0 °C (32 °F) the readability of the LC display will be limited.

#### 8.2.2 Ambient temperature range

- 20 °C to + 60 °C (-4 °F to 140 °F)

#### 8.2.3 Storage temperature

-25 °C to + 60 °C (-13 °F to 140 °F)

#### 8.2.4 Ingress protection

Standard housing SG1, IP 68 (NEMA 6P)

Explosion-proof electronics housing

Terminal compartment: with terminals and "Increased safety" type of protection.

	<p><b>Warning:</b> Ingress protection IP 68 is only achieved if suitable and tightly screwed down cable glands or conduit are used. If the cable glands are only tightened manually water may leak into the terminal compartment in the housing.</p>
---	--

	<p><b>Danger:</b> Particular care must be taken if the window in the housing becomes fogged over or discolored because moisture, water or product might seep through the wire sheath into the terminal compartment in the housing.</p>
---	--

	<p><b>Warning</b> Electromagnetic compatibility is only achieved if the electronics housing is closed. Leaving the enclosure open can lead to electromagnetic disturbances.</p>
---	---

### **8.3 Process conditions**

#### **8.3.1 Fluid temperature**

- 40 °C to + 260 °C (-40 °F to 500 °F)

The data sheet/rating plate of the connected transmitter must be observed.

#### **8.3.2 Physical state**

Liquid product (maximum density 2 kg/l (125lb/ft<sup>3</sup>))

Gaseous product (minimum density 0.002 kg/l in operating state)

#### **8.3.3 Viscosity**

0.3 to 50,000 mPas (0.3 to 50,000cP)

The data sheet of the connected transmitter must be observed.

#### **8.3.4 Fluid temperature limit**

260 °C (500 °F)

The data sheet of the connected transmitter must be observed.

#### **8.3.5 Flow rate limit**

See sensor data sheet in Section 2.4.2 CMM flow ranges on page 7.

#### **8.3.6 Pressure loss**

See sensor data sheet in Section 2.4.5 Pressure loss CMM on page 9.

## 9. Construction details

### 9.1 Type of construction/dimensions

#### Horizontal pipe mounting - SG1

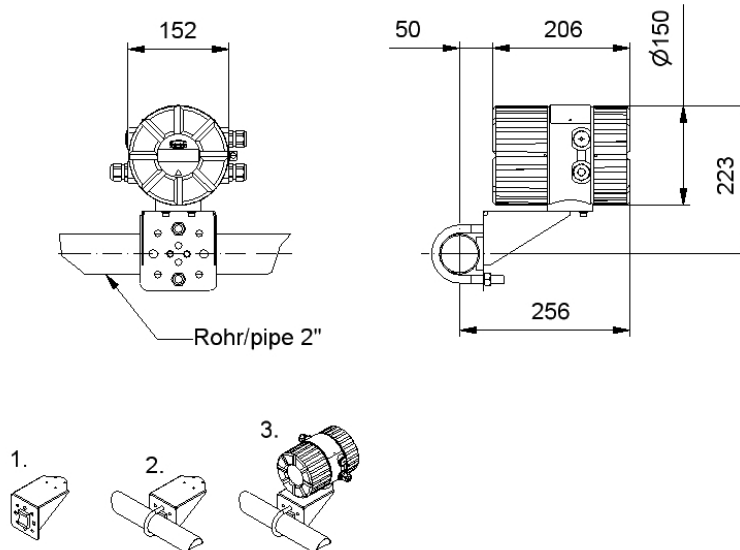

1. Mount pipe to carrier.
2. Tighten U-bolt clamp around pipe.
3. Mount transmitter onto carrier.

#### Vertical pipe mounting - SG1

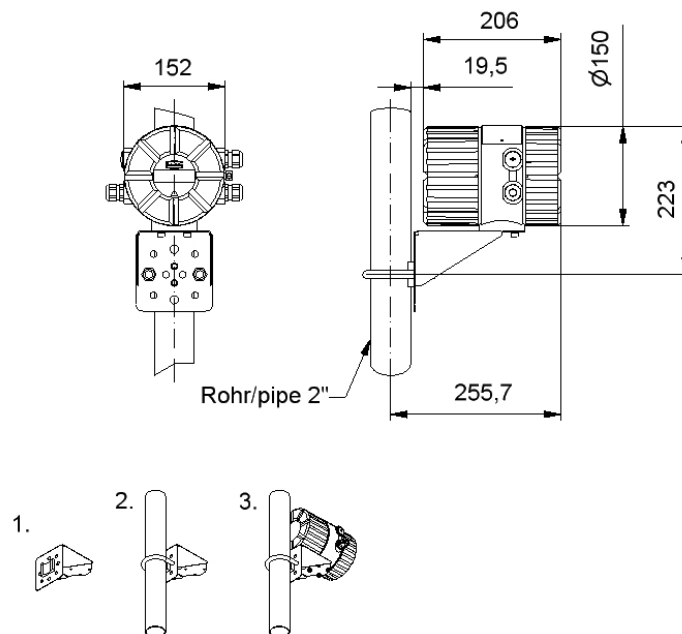

#### Separate mounting – SG1

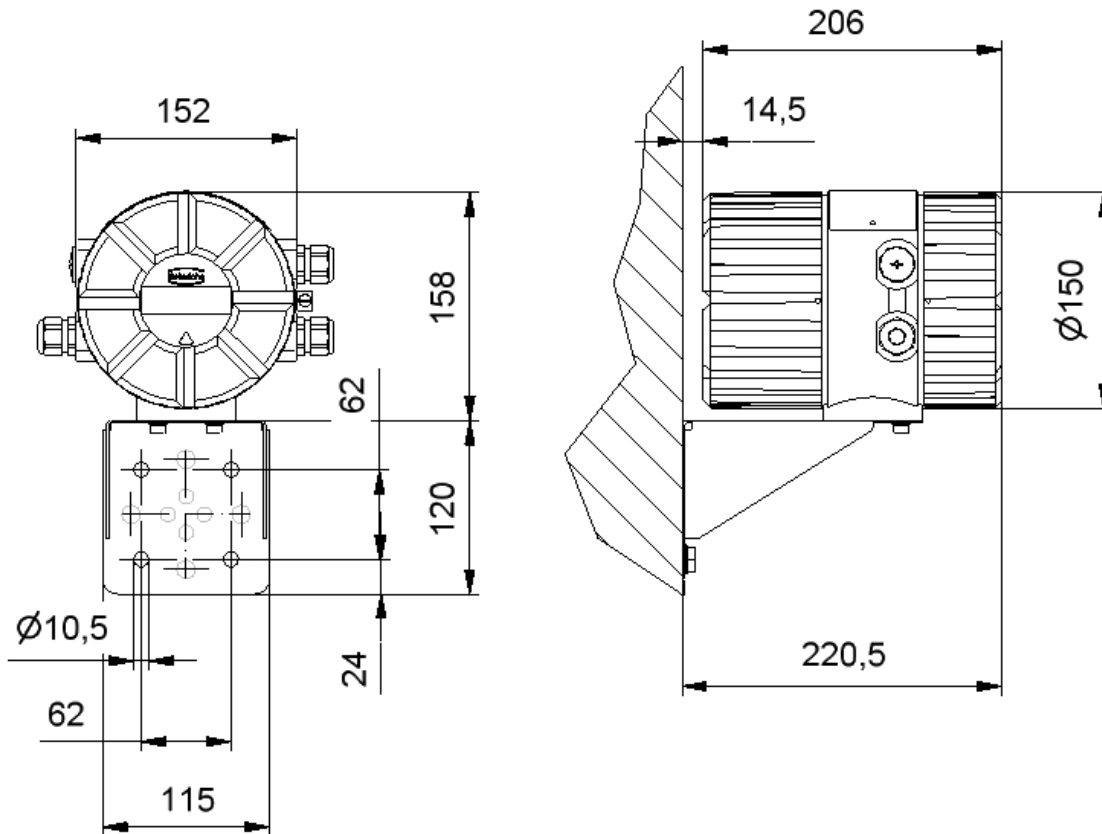

## 9.2 Weight

4.5 kg (10 lbs) (separate CT transmitter)

## 9.3 Material

Housing: GK Al Si 12 MG wa, passivated in chromic acid before being varnished

## 9.4 End connection

Direct (wireless) connection with the sensor or cable connection. For further details see Section 2.7 Connection to the transmitter on page 15, Section 9.5.2.1 Wiring diagram for the integral mount configuration of sensor and CT on page 35 and Section 9.5.2.2 Wiring diagram for the remote mount configuration of sensor and CT on page 36.



## 9.5 Electrical connection

Auxiliary power	90 V - 265 V AC 24 V AC 19 V to 36 V DC	+ 20 %, - 20 %	50/60 Hz 50/60 Hz
Power input	7.5 VA		
Main fuse:	5x20 mm IEC 60127-2,V		
	Main voltage	r. Current	rated voltage breaking capacity
	90V ... 265V AC	400mAT	250V AC 1500A / 250V AC
	24V AV	800mAT	250V AC 1500A / 250V AC
	19V ... 36V DC	800mAT	250V AC 1500A / 250V AC

### 9.5.1 CT connections

Lines

Designation	Terminal designation	Type of protection		Standard
		EEx ia	EEx e	
				(Not Ex)

<b>Power supply</b>	L(+), N(-),PE		x	x
---------------------	---------------	--	---	---

<b>Sensor lines</b>				
SENSOR1 +	1	x		x
SENSOR1 -	2	x		x
SENSOR2 +	3	x		x
SENSOR2 -	4	x		x
TIk-	5	x		x
Temperature sensor -	6	x		x
Temperature sensor +	7	x		x
TIk+	8	x		x
EXCITER1	9	x		x
EXCITER2	10	x		x
Shield	Shield	x		x

Designation	Terminal designation	Type of protection		Standard (Not Ex)
		EEx ia	EEx e	
<b>Signal outputs</b>				
Current 1, 0/4 to 20mA with HART®	11 and 12	x		x
	41 and 42		x	
Current 2, 0/4 to 20mA	13 and 14	x		x
	43 and 44		x	
Binary output 1 (passive pulse)	16 and 17	x		x
	46 and 47		x	
Binary output 1 (active pulse)	45 and 48		x	
	15 and 18			x
Binary output 2 (status or second passive pulse output for custody transfer operations)	19 and 20	x		x
	49 and 50		x	
Option Binary output 3 (status output during custody transfer operations)	33 and 34	x		x
	53 and 54		x	
Profibus PA option	39 (A) and 40 (B)	x		
Control unit BE	Shield, -, +	x		x
<b>Alternatives for current output 2</b>				
Binary input	21 and 22	x		x
	51 and 52		x	
Modbus/Profibus DP with RS 485-IS	35 (A) and 36 (B) (not currently available)	x		x
Profibus DP	37 (A) and 38 (B) (not currently available)		x	

- Since the signal outputs cannot be activated simultaneously owing to the limited number of terminals available, one of the aforementioned options must be selected. **Field bus devices (Profibus PA) are not outfitted with an analog or impulse output.**
- A maximum of 8 signal output terminals is available (in addition to the terminal for the control unit and Profibus PA).
- “Increased safety” type of protection signal outputs are to be connected only to “Extra low voltage” degree of protection circuits with safe electrical isolation in accordance with DIN VDE 0100 part 410.
- **Under no circumstances are “Increased safety” signal outputs to be combined with “Intrinsic safety” signal outputs.**
- If interface output RS 485 (under development and not currently available), which is only available in an “Increased safety” model, is selected, all signal outputs must also have this type of protection.
- If “Control input” or “RS 485 interface” are selected, current output 2 is not supplied.
- If the sensor and transmitter are interconnected using a cable, the following cable is to be used: **SLI2Y (SP) CY 5 x 2 x 0.5 mm (for explosion-proof applications, grey for non-explosion proof applications).**

**9.5.2 Wiring diagram**

**9.5.2.1 Wiring diagram for the integral mount configuration of sensor and CT**

**Supply and end connections  
of the CT transmitter**

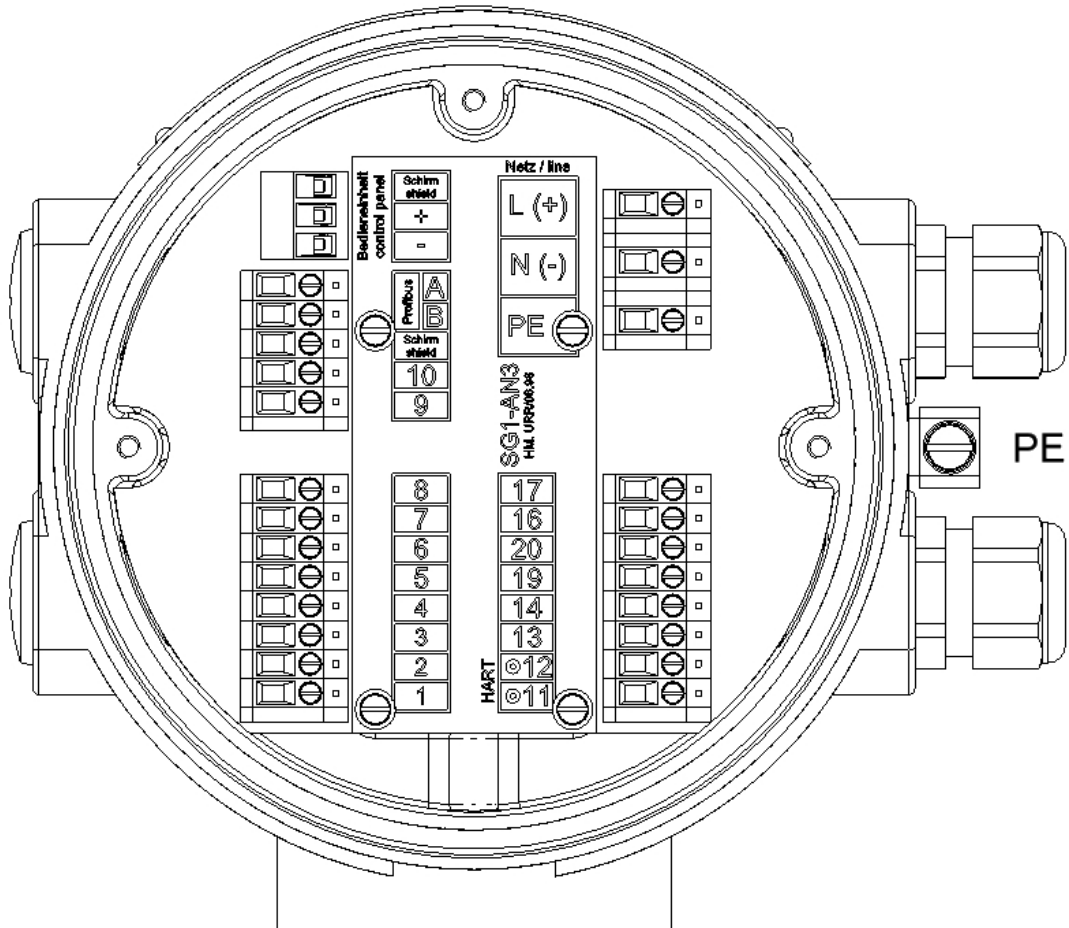

Process outputs wiring			
Standard EEx ia / Not Ex	Standard EEx e	Custody transfer	Modbus (planned) (RS485 - IS)
17 + Binary output 1	47 + Binary output 1	17 + Binary output 1	17 + Binary output 1
16 - (pulse/frequency)	46 - (pulse/frequency)	16 - (pulse/frequency)	16 - (pulse/frequency)
20 + Binary output 2	50 + Binary output 2	20 + Binary output 2	20 + Binary output 2
19 - (status output)	49 - (pulse/frequency)	19 - (pulse/frequency)	19 - (pulse/frequency)
14 + Current output 2	44 + Current output 2	34 + Binary output 3	36 B RS485
13 - (0/4-20 mA)	43 - (0/4-20 mA)	33 - (status output)	35 A (Modbus)
12 + Current output 1	42 + Current output 1	12 + Current output 1	12 + Current output 1
11 - (0/4-20 mA HART®)	41 - (0/4-20 mA HART®)	11 - (0/4-20 mA HART®)	11 - (0/4-20 mA)

Note: RS 485 not currently available

**9.5.2.2 Wiring diagram for the remote mount configuration of sensor and CT**

Cable: Non-explosion proof applications SLI2Y(ST)CY 5 x 2 x 0.5 mm<sup>2</sup> grey (max. 300 m)  
 Explosion-proof applications SLI2Y(ST)CY 5 x 2 x 0.5 mm<sup>2</sup> blue (max. 300 m)

The outer shield is connected to the cable glands at both ends, the inner shields are connected to each other and connected to the "Schirm / shield" terminal.

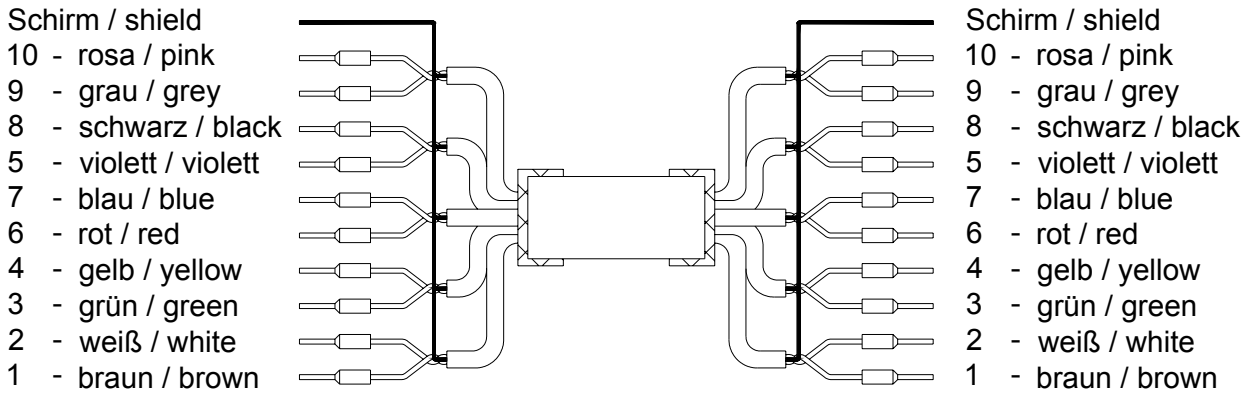

CMM, CMB, CMU with WAGO terminals  
 For terminal assignment, see Section 9.5.1 CT connections

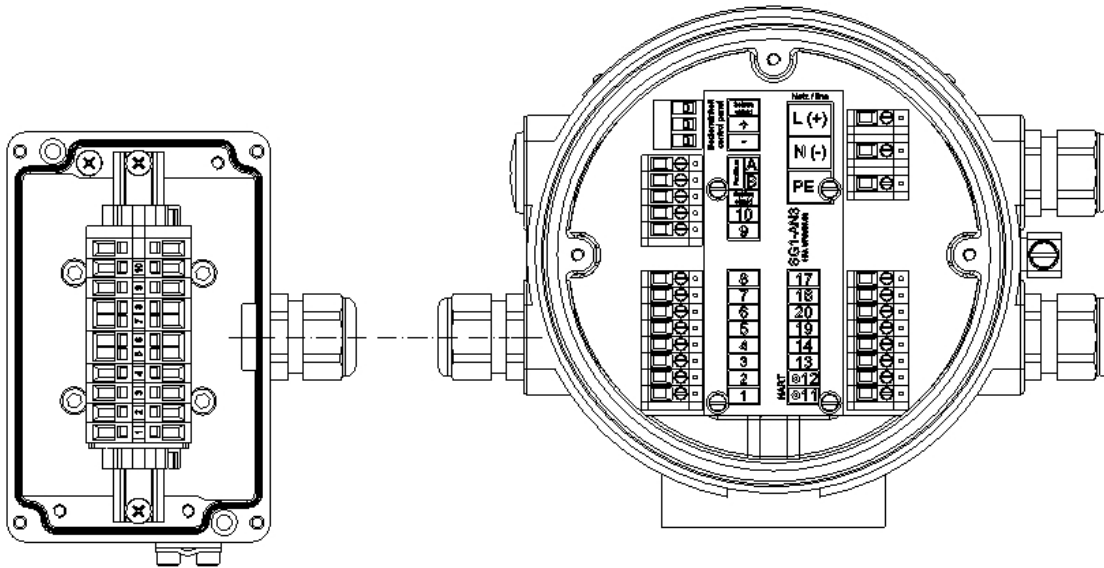

Advices to cable glands: See also 8.1 "Installation conditions and cable glands" at page 29.

CMM, CMB, CMU with limit circuit and WAGO terminals  
For the terminal assignment, see Section 9.5.1 CT connections

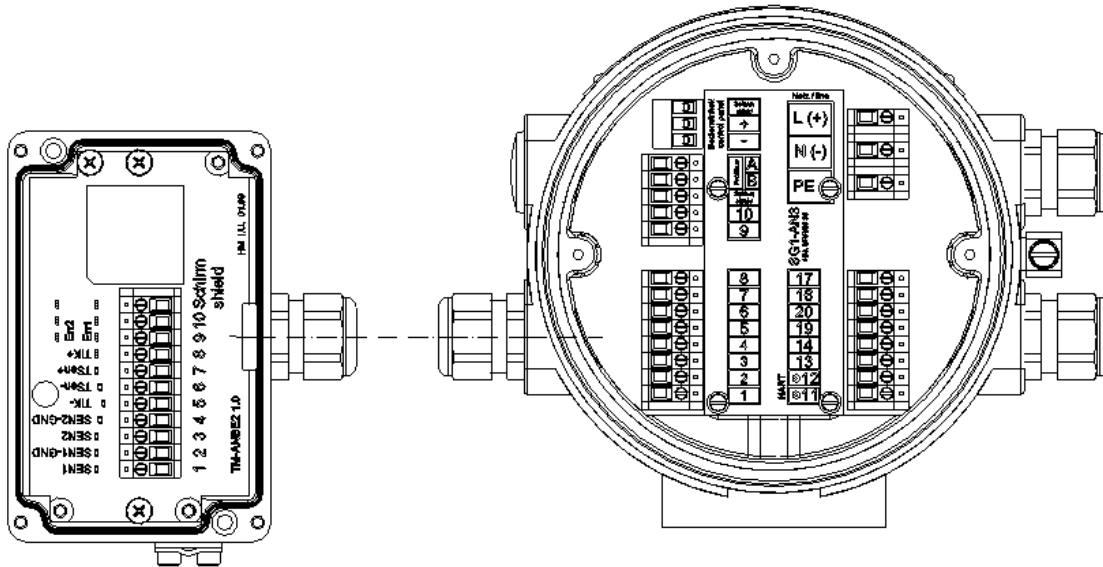

Cable glands: See also 8.1 “Installation conditions and cable glands” at page 29.

### 9.5.3 HART®

A number of options are available for HART® communication. However, for all these options loop resistance must be less than the maximum load specified in Section 6.3 Load (on page 28). The HART® interface is connected via terminal 11 and 12 or 41 and 42 with a minimum load impedance of 250 ohms.

For information regarding operation of the transmitter using the HART® hand-held terminal, see “Operation of the CT transmitter using the HART® hand-held terminal.”

### 9.5.4 Communication via SensorPort

SensorPort is the configuration software that is used to operate HART® or Profibus PA compatible devices.

To connect a desktop or laptop computer to the CT, a HART® interface is required in addition to communication software such as SensorPort. The HART® interface, which has two connections, converts the levels of the RS 232 interface into an FSK signal (frequency-shift keying). These connections consist of 9-pin sockets at the interface for the RS 232 connection, as well as a two-core cable with two mini terminals for current loop 1 in the transmitter.

The interface can be also installed in a separate control cabinet.

## 10. Control unit BE2

### 10.1 Introduction

The CT transmitter can be operated using control unit BE2, a desktop or laptop computer in conjunction with SensorPort software, or via HART® Communicator.

In the following, transmitter operation and parameterization using control unit BE2 (normally integrated into the terminal compartment) are described. The control unit can also be connected to the transmitter using an intrinsically safe cable that is up to 200 m in length. This allows a point-of-use display to be installed in a control room so that readings, counter status and settings can be accessed ergonomically.

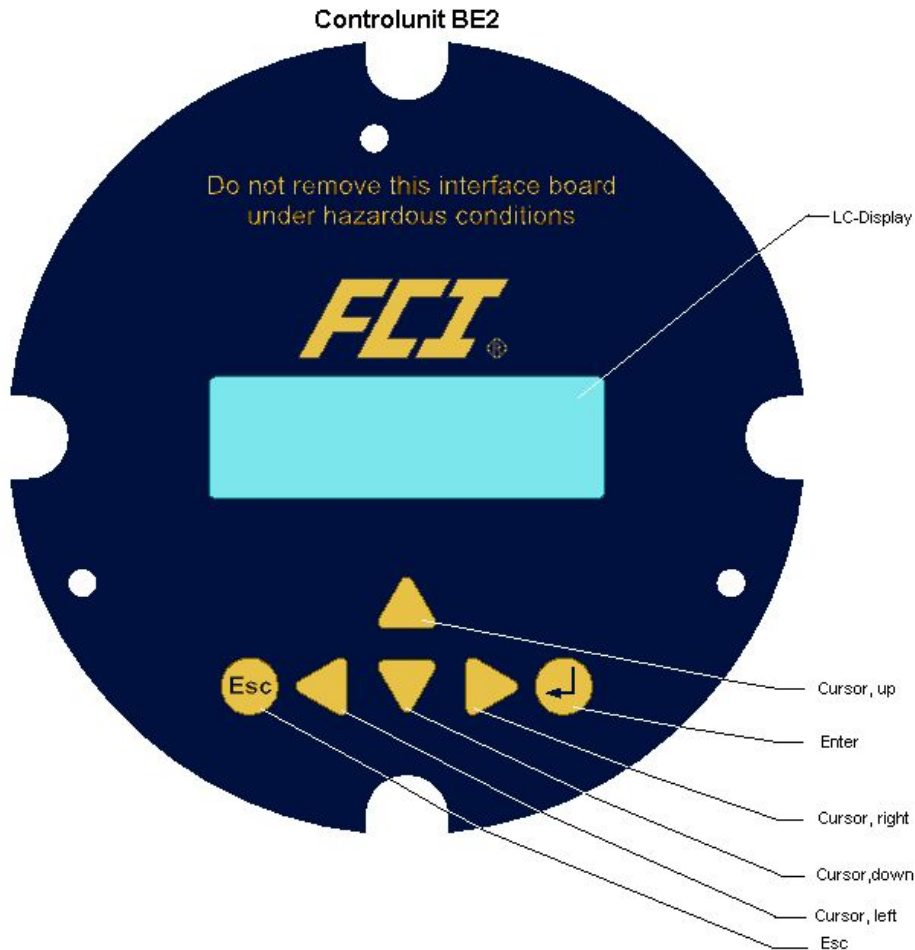

### 10.2 Display

Control unit BE2 in the CT has an integrated alphanumeric display with two 16-character lines (format 16 x 60 mm). Measurement data and settings can be read directly from this display.

The LCD display is designed to be operated at temperatures ranging from  $-20\text{ }^{\circ}\text{C}$  ( $-4\text{ }^{\circ}\text{F}$ ) to  $+60\text{ }^{\circ}\text{C}$  ( $140\text{ }^{\circ}\text{F}$ ) without incurring any damage. However, at freezing or near-freezing temperatures, the display becomes slow and readability of the measured values is reduced. At temperatures below  $-10\text{ }^{\circ}\text{C}$  ( $14\text{ }^{\circ}\text{F}$ ), only static values (parameter settings) can be displayed. At temperatures exceeding  $60\text{ }^{\circ}\text{C}$  ( $140\text{ }^{\circ}\text{F}$ ), contrast decreases substantially on the LCD and the liquid crystals can dry out.

## 11. Certificates and approvals

CE marking: The measuring system complies with the legal requirements of the Electromagnetic Compatibility Directive 89/336/EC and the Explosion Protection Directive 94/9/EC.  
The CE mark indicates that the device complies with the aforementioned directives.

Ex approval: **CT transmitter:**  
BVS 05 ATEX E 146 X  
EEx de [ia] IIC / IIB T6 - T3  
EEx d [ia] IIC / IIB T6 - T3

Sensor:  
See Section 2.9 Sensor CMM approvals on page 23.

## 12. Standards and authorizations

### 12.1 General standards and directives

EN 60529 Ingress protection class (IP code)  
EN 61010 Safety requirements for electrical metering, control and laboratory devices  
NAMUR guideline NE21, Version 10/02/2004  
Explosion Protection Directive 94/9/EEC  
OIML R 105 and DIN 19217 (international recommendations for custody transfer operations)

### 12.2 Electromagnetic compatibility

EMC Directive 89/336/EEC  
EN 61000-6-2:1999 (immunity for industrial environments)  
EN 61000-6-3:2001 (emissions residential environments)  
EN 55011:1998+A1:1999 group 1, class B (emitted interference)  
DIN EN 61000-4-2 to DIN EN 61000-4-6  
DIN EN 61000-4-8  
DIN EN 61000-4-11  
DIN EN 61000-4-29  
DIN EN 61326

### 12.3 Ex-Approval transmitter

Explosion Protection Directive 94/9/EEC  
EN 50014 General guidelines  
EN 50018 Flameproof enclosures "d"  
EN 50019 Increased safety "e"  
EN 50020 Intrinsic safety "i"  
EN 50284 Group II Category 1G

Version / printed: 10.04.2006 / 10.04.2006  
Part No 06EN003383 rev. 1.6

---

FCI Fluid Components International LLC  
1755 La Costa meadows Drive  
San Marcos, CA 92078  
Phone: 1 - 760 - 744 - 6950  
Fax: 1 - 760 - 736 - 6250  
Internet: [www.fluidcomponents.com](http://www.fluidcomponents.com)  
E-mail : [info@fluidcomponents.com](mailto:info@fluidcomponents.com)

We reserve the right to make changes  
without notice in the dimensions, weights  
and technical specifications.

File:  
CMM\_CT\_GB\_01\_FCI.DOC

Page 40 of 40

---