

ST75/ST75V MASS FLOW METER Installation and Operation Guide

Pre-Installation

Serial Number Alignment

The ST75 and ST75V (Vortab) can be specified with integral or remote electronics. The flow element has a serial number etched into the side of the HEX as shown on Figure A. In addition, the enclosure tag also shows serial and model numbers. The associated transmitter circuit card has a serial number noted on the board as shown in Figure B. The flow sensor and transmitter circuit have been calibrated as a matched set and should be paired together in service unless otherwise approved by a factory technician.

Flow Direction Alignment

All sensor elements have a flow arrow indicator marked on the element assembly at the reference HEX flat. These flow elements have been calibrated in a particular direction and are designed to be used in service with the flow arrow going in the same direction as flow in the pipe stream. The flow element has been calibrated directly in the pipe tee or tube tee with careful consideration for orientation and insertion depth. Removal from the tee section while physically possible is not recommended unless authorized by a factory technician.

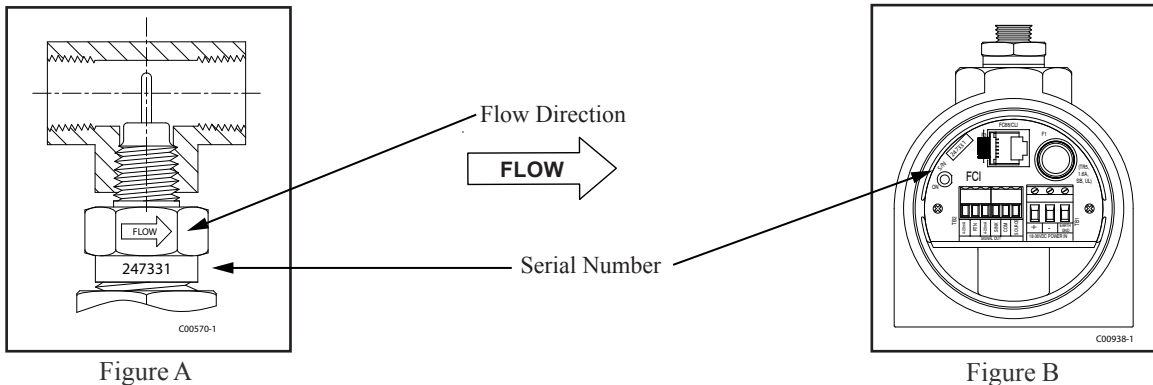

Recommended Straight Run

To optimize flow meter system performance, FCI recommends installation with a minimum of 20 diameters upstream straight run and 10 pipe diameters of downstream straight run. Where straight run limitations significantly reduce the available pipe diameters, FCI uses flow conditioners to produce a transferable flow profile from the calibration installation to actual field installations. FCI's proprietary AVAL software is available to make flow meter installation evaluations where straight run limitations are considered. See Figure C for recommended installation.

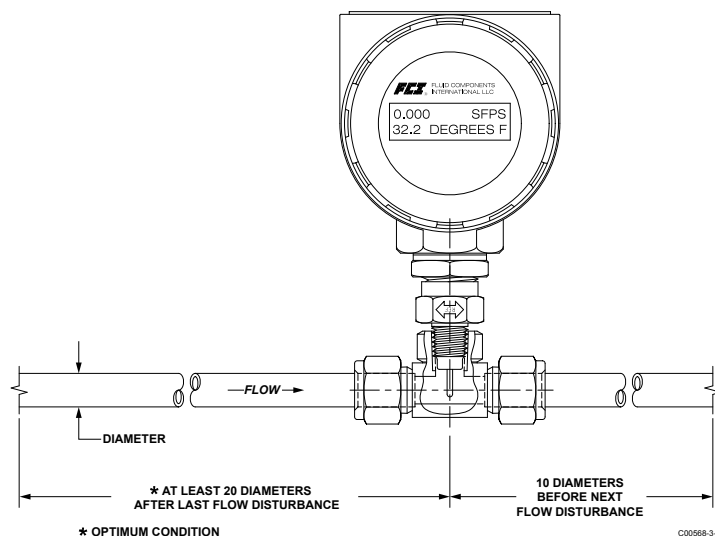

Figure C - Recommended Straight Run Condition

Specifications

Media Compatibility: Air, compressed air, nitrogen, oxygen, argon, CO₂, ozone, other inert gases, natural gas, and other hydrocarbon gases, hydrogen.

Pipe/Line Size Compatibility: 1/4" to 2" [6 mm to 51 mm]

Instrument

ST75/ST75V Range:*

NPT Line Size	1/4"	1/2"	3/4"	1"	1 1/2"	2"
Min SCFM	0.04	0.13	0.22	0.35	0.85	1.40
Min [NCMH]	[0.07]	[0.22]	[0.38]	[0.59]	[1.44]	[2.38]
Max SCFM	17.34	50.64	88.88	139.95	539.31	559.27
Max [NCMH]	[29.47]	[86.04]	[151.00]	[237.78]	[576.48]	[950.20]

Tubing Line Size	1/4"	1/2"	1"
Min SCFM	0.01	0.05	0.25
Min [NCMH]	[0.01]	[0.09]	[0.42]
Max SCFM	3.02	21.15	99.08
Max [NCMH]	[5.14]	[35.94]	[168.33]

* Actual range subject to gas type and specific conditions.

Accuracy:

ST75: ±2% of reading, ±0.5% of full scale
 Optional: ±1% of reading, ±0.5% of full scale
ST75V: ±1% of reading, ±0.5% of full scale

Repeatability: ± 0.5% of reading

Temperature Compensation:

Standard: 40 to 100 °F [4 to 38 °C]
 Optional: 0 to 250 °F [-18 to 121 °C]

Turndown Ratio: 10:1 to 100:1

Agency Approvals:

ATEX/IECEx: II 2 G Ex db IIC T6...T1 Gb
 II 2 D Ex tb IIIC T85°C...T300°C Db; IP66/IP67
 Ta = -40°C to +65°C

FM, FMc: Class I, Div 1, Groups B, C, D
 Class I, Div 2, Groups A, B, C, D
 Class II/III Div 1, Groups E, F, G
 Type 4X, IP66

CRN No.: 0F0303

Warranty: One Year

Flow Element

Installation: In-line Tee or Spool.

Material of Construction: All-welded 316L stainless steel flow element with Hastelloy-C thermowells; 316L stainless steel NPT, tube fittings, and flanges.

Maximum Operating Pressure:

ST75: Pipe Tee [NPT female]: 240 psi [16.5 bar(g)]
 Tube Tee: 600 psi [41 bar(g)]

ST75V: 600 psi [41 bar(g)]

Temperature: Operating: 0 to 250 °F [-18 to 121 °C]

Process Connection:

ST75: Pipe Tee [NPT female]: 1/4", 1/2", 3/4", 1", 1 1/2" or 2"
 Tube Tee: 1/4", 1/2" or 1"

ST75V: Female NPT, Male NPT, Flange
 1/4", 1/2", 3/4", 1", 1 1/2" or 2"

Transmitter

Enclosure: NEMA 4X [IP67], aluminum, dual conduit ports with either 1/2" Female NPT or M20x1.5 entries. Polyester powder coated.

Output Signals:

- (2) 4-20 mA user assignable to flow rate and/or temperature
- (1) 0-500 Hz pulse for total flow

Communication Port: RS232C standard.

Input Power:

- DC:** 18 VDC to 36 VDC (9.6 watts)
- AC:** 85 VAC to 265 VAC (10 watts)

Operating Temperature Range: 0 to 140 °F [-18 to 60 °C]

Digital Display (Optional): Two-line x 16 characters LCD. Displays measured value and engineering units. Top line assigned to flow rate. Second line is user assignable to temperature reading, flow totalizer or alternating. Display can be rotated in 90° increments for optimum viewing orientation.

FCI flow meters may be installed with less than the recommended straight run, but at the risk of limiting performance. FCI offers VORTAB flow conditioners for use in applications that have significant straight run limitations. FCI uses the AVAL application modeling software to predict meter performance in each installation. AVAL outputs are available to review prior to order placement and will indicate performance expectations both with and without flow conditioning.

Flow Element Installation



Caution: The element is shipped installed in the tee, with the element specifically oriented for inline installation. Do not remove the sensing element from the tee section during installation as calibration can be adversely affected.

Process Connections

The ST75 is available in pipe tee configurations with NPT threads and tubing tees with a compression fitting suitable to clamp down on concentric smooth surface tubing. The pipe tee versions are standard 150# class rated tees suitable for service up to 150 PSIG at the process temperature maximum of 250 °F (121 °C). The compression fitting material offered in the tube type configuration is rated for 250 PSIG service.

Pipe Tee Installation: With pipe extensions properly cut to length and the appropriate sealing materials used on the threads, install flow element section by slowly rotating the configuration until firmly secure on the pipe section. Complete by installing opposing end pipe section using care to firmly secure the element assembly either in a top mount or side mount position.

Tube Tee Installation: Clean all mating surfaces of the tee fitting, ferrules and the flow tube. Insert the flow tubing into the tee fitting. Make sure the tubing rests firmly in the fitting counter bore seat. Tighten the nut on both ends of the tee by hand. Hold the fitting body steady with a backup wrench, tighten the fitting nuts 1-1/4 turns, from hand tight baseline.

The ST75V is available in with flow tube configurations offering male and female NPT threads, ANSI flanges and DIN flanges. The flow tube assemblies are rated for service up to 240 PSIG at the process temperature maximum of 250 °F (121 °C).

NPT Flow Tube Installation: With pipe extensions properly cut to length and the appropriate sealing materials used on the threads, install flow element section by slowly rotating the configuration until firmly secure on the pipe section. Complete by installing opposing end pipe section using care to firmly secure the element assembly either in a top mount or side mount position.

Flanged Installation: Clean all mating surfaces. Install appropriate sealing gasket between mating flanges. Tighten flange mating hardware to meet system sealing requirements.

See Appendix C for instrument outline dimensional details.

Instrument Wiring

Before opening the instrument to connect power and signal observe the following ESD precautions:

Use a wrist band or heel strap with a 1 megohm resistor connected to ground. If the instrument is in the shop setting, use a static conductive mat on the work table or floor with a 1 megohm resistor connected to ground. Connect the instrument to ground. Apply antistatic agents such as Static Free made by Chemtronics (or equivalent) to hand tools to be used on the instrument. Keep high static producing items away from the instrument.

The above precautions are minimum requirements. The complete use of ESD precautions can be found in the U.S. Dept. of Defense Handbook 263.



Warning: Only qualified personnel are to wire or test this instrument. The operator assumes all responsibility for safe practices while wiring and troubleshooting.

Install an input power disconnect switch and fuse near the instrument to interrupt power during installation and maintenance. Operator must have power disconnected before wiring.

See the “Specific Conditions of Use” and “Safety Instructions” sections in Appendix A for use of the ST75/ST75V (AC and DC versions) in Hazardous Areas Category II (Zone 1).

Input Power

The ST75/ST75V is available with both VDC and VAC input power configurations. Customers selecting VDC input power will have a VDC input board only. Similarly, the VAC power board is supplied only with VAC powered units. In addition, both boards are marked for either AC or DC power. Only connect the power specified on the wiring module as shown on Figures D and E respectively. Both VAC and VDC inputs require a Gnd wire to be connected. Input power terminal blocks accept 14-26 AWG wire.

Make sure that power is OFF before wiring the instrument. Pull the power and signal output wires through the port, using care not to damage wires. FCI recommends using crimp lugs on the output wires to ensure proper connection with the terminal strip. Connect the output wires as shown on Figures D and E. Note that when the 4-20 mA outputs are used simultaneously, a single return lead is used.

Analog Output

4-20 mA: The instrument is provided with two 4-20 mA outputs. By default Output 1 is configured for flow and Output 2 is configured for temperature. Terminal blocks accept 14-28 AWG wire, 500 ohms max load per output.

Pulse Output Activation

The ST75/ST75V provides a pulse output feature. Instruments ordered with volumetric or mass flow units are factory set with totalizer and pulse output activated. The mode can be changed in the field. Source and sink output wiring is shown in Figures D and E below. Though only one configuration is shown with the VAC and VDC power supplies, the source or sink can be used with either power input.

Sink Mode: 40 VDC max., 150 mA max. Customer-supplied power source.

Source Mode: 15 VDC output, 50 mA max.

VDC Power Connection

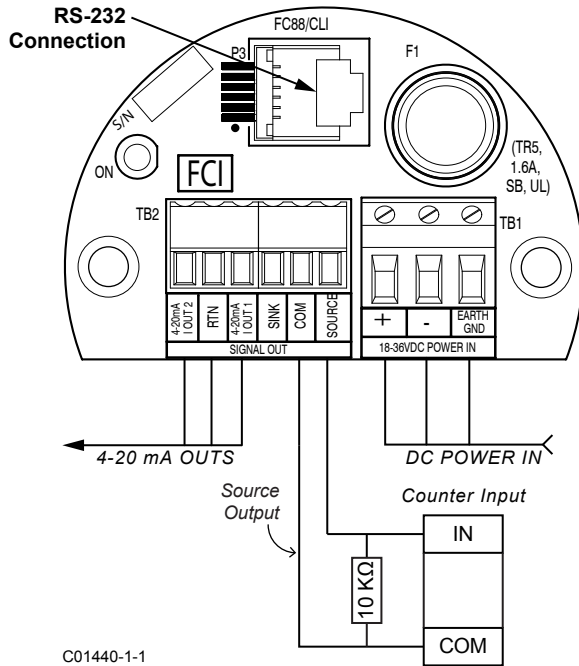

Figure D

VAC Power Connection

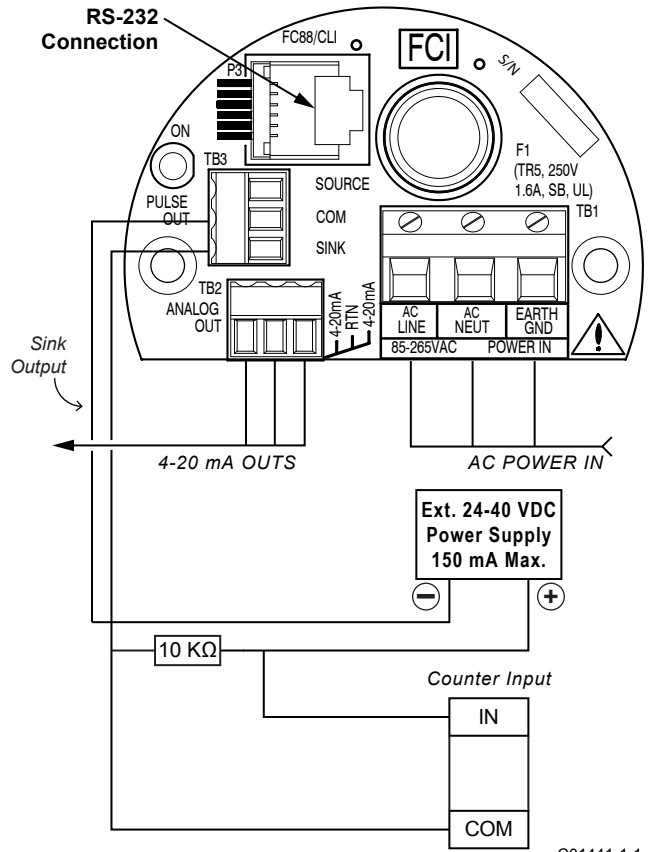

Figure E

VDC Power
 As Shown:
 18-36 VDC power connected with Gnd
 4-20 mA connected for flow and temperature
 Pulse Out in source mode
Note: In source mode, 15 VDC output max., 50 mA max.

VAC Power
 As Shown:
 85-265 VAC power connected with Gnd
 4-20 mA connected for flow and temperature
 Pulse Out in sink mode
Note: In sink mode, 40 VDC max., 150 mA max. customer-supplied power source.

Power Dissipation

DC Version

Power dissipation values under nominal conditions:

- Instrument (Electronics + Sensor): 4.5 watts
- Sensor only: 0.25 watts

Power dissipation values under maximum load conditions:

- Instrument (Electronics + Sensor): 6 watts
- Sensor only: 0.30 watts

AC Version

Power dissipation values under nominal conditions:

- Instrument (Electronics + Sensor): 11.6 watts
- Sensor only: 0.25 watts

Power dissipation values under maximum load conditions:

- Instrument (Electronics + Sensor): 12 watts
- Sensor only: 0.30 watts

Setup Interface

All parameters on this meter are set through the RS232 interface connection (P3 plug). The RS232 interface allows the instrument to be set up with either an FC88 hand held communicator or a computer. The FC88 is powered through the meter and comes with the serial interface cable. If a computer interface is used, an adapter (RJ to 9-pin PC serial port) is required. The adapter can be obtained from FCI: Part No. 014108-02.

Using a serial comm/terminal program (e.g., HyperTerminal, TeraTerm, Putty, etc.) configure the PC's serial port (the one intended to be connected to the instrument) as listed in the table below.

COM Port Number:	Number of COM port connected to instrument (COM1, COM2, etc.)
Baud Rate:	9600
Number of Bits:	8
Stop Bits:	1
Parity:	None
Flow Control:	None
Terminal Emulation:	VT100

After configuring the serial port (and making the PC-to-instrument connections) start a communications session with the applicable serial port. Enter any of the meter's single letter commands in the program's terminal window to execute a function. See "Table 5. ST75/ST75V List of Single Letter Commands" on page 23 (Appendix B) for the complete command list.

An additional command line interface (CLI) is available through the RS232 port. This interface is accessed with the "Y" command using a computer or FC88. The command line password is "357". See "Table 6. ST75/ST75V List of CLI Commands" on page 23 (Appendix B) for command line details.

Start-up and Commissioning

1. Verify all input power and output signal wiring is correct and ready for initial power start-up.
2. Apply power to the instrument. The instrument initializes in the Normal Operation Mode with all outputs active. An instrument with the display option indicates flow with the factory-set flow units. Allow 10 minutes for the instrument to warm up and reach thermal equilibrium.



Note: Thirty (30) second warm-up required before calibration check.

The following FC88 commands are typical commands that are used during start-up and commissioning:

Command	Name	Description
T	Normal Operation Mode	All outputs are active
Z	Flow Unit Set-up	Select Flow Units (4 English, 4 Metric) Pipe Dimensions
W	Totalizer	Enable/Disable
V	Output Configuration	Select one of 4 Configurations: Pulse and/or Alarm-Pulse factor and/or setpoint
F	K-Factor (default = 1)	Flow factor
N	Warm Reset	Re-initialize C/B
S	Totalizer Menu	Enables W menu (Option)

When placed in service, the instrument indicates 0.000 for no process flow.

Flow Unit Modification

Example: SCFM Flow Units and 3 inch Sch 40 round pipe size set up:

Enter	Display	Description
Enter	menu: >	From Normal Operation Mode
Z	E for English M for Metric >	Flow Unit Set-Up menu
E	0=SFPS, 1=SCFM, 2=SCFH, 3=LB/H, 4=GPM #	English units
1	R round duct or S rectangular>	Select standard cubic ft./minute (SCFM)
R	Dia.: 4.0260000 Change? (Y/N)>	Select Round Duct
Y	Enter value: #	
3.068	area: 7.3926572 CMinflow: 0.0000000 Change? (Y/N)>	3 inch Sch. 40 pipe I.D.
N	Maximum flow: 462.04 Enter to continue	
Y	Cmaxflow: 462.04 Change? (Y/N)>	
Y	#	
462.04	CMintemp (F): -40.00000 Change? (Y/N)>	
N	CMaxtemp (F): 250.00000 Change? (Y/N)>	
N	Percent of Range is: OFF Change to ON?>	
N	LCD Mult Factor x1 Change? (Y/N)>	
N	100.0 SCFM	Instrument ends up in Normal Operation Mode

RS232 / FC88

Menu Control and Organization

Most entries require at least two keystrokes; a capital letter and the [ENTER] key, or one or more numbers and the [ENTER] key. All user entries begin at the input mode prompt “>”, except when the instrument is in the Main Function Mode (just press the desired function letter and [ENTER] to make an entry).

Backspaces are made using the backspace [BKSP] key. Some entries are case sensitive between numbers and letters. Be sure the SHIFT key is pressed to indicate the correct case. A square after the prompt caret indicates the FC88 is in lower case. A slightly raised rectangle in the same spot indicates the FC88 is in the upper case.

It is recommended that the FC88 be plugged into the instrument before power is applied. If the FC88 is plugged in while the instrument power is on and the FC88 does not respond, press [ENTER]. If there is still no response press [N] or cycle the power.



Note: The Zero and Span may be changed from the original calibration, provided the new values are within the original calibrated range; i.e., if the original calibration was 1 to 100 SCFM (4-20 mA), the new zero (4 mA) must be equal to or greater than 1 SCFM, and the new span (20 mA) must be equal to or less than 100 SCFM.

Some entries require a Factory pass code. If this occurs contact FCI Field Service to continue programming the instrument. The instrument will prompt the user when this is necessary. Do not change any parameters that require this code unless there is an absolute understanding of the instrument’s operation. The user cannot exit some routines unless all entries are completed or the power is cycled.

The top level of the menu is shown in “Table 5. ST75/ST75V List of Single Letter Commands” on page 23. Enter the command letter mnemonic as listed in the tables below and in Appendix B to run a command. Exit a command at any time by entering “Q” [ENTER] in the menus D, K, V, W, or Z.

Table 1. Diagnostics and Factory Settings

C Calibration Information	Display only: A/D, Delta-R, Ref-R data values
D Diagnostics	Display only: List of unit parameters.
K Factory Calibration Settings	Display only: Cal. parameters; i.e., linearization and temperature compensation coefficients.
R Factory Reset	Replaces user data with factory calibration data.

Table 2. Z Menu – Units and Scaling Setup

Units		
<i>Select</i>	E=English	M=Metric
<i>Select</i>	0= SFPS	5 = SMPS
<i>or</i>	1 = SCFM	6 = NCMH
<i>or</i>	2 = SCFH	7 = NCMM
<i>or</i>	3 = LBS/H	8 = KG/H
<i>or</i>	4 = GPM	9 = LPM
<i>or</i>		10 = SCMH
<i>or</i>		11 = NMPS
<i>or</i>		12 = SCMM
For Volumetric or Mass Flow		
<i>Select</i>	R = Round pipe or duct	
<i>or</i>	S = Square duct	
<i>Set</i>	Diameter or Wide X High (in inches or mm)	
<i>Set</i>	CMaxflow = Maximum flow rate (span)	
<i>Set</i>	CMinflow = Minimum flow rate (zero)	

Note: Changing units requires rescaling the unit (set new zero and span).

Table 3. V Menu – Output Configuration Setup

Select		1	2	3	4
4-20 mA Output Configuration	<i>Select</i> →	4-20 mA Output #1 = Flow 4-20 mA Output #2 = Temp	4-20 mA Output #1 = Flow 4-20 mA Output #2 = Flow	4-20 mA Output #1 = Temp 4-20 mA Output #2 = Flow	4-20 mA Output #1 = Temp 4-20 mA Output #2 = Temp
Select NAMUR Mode	<i>Select</i> →	1 NAMUR: OFF		2 NAMUR: Low	
Select Source/Sink (Pulse) Output Configuration	<i>Select</i> →	1 Source = Pulse Sink = Pulse	2 Source = Pulse Sink = Alarm1	3 Source = Alarm0 Sink = Pulse	4 Source = Alarm0 Sink = Alarm1
	<i>Set</i> →	PFactor	PFactor	PFactor	Switchpoint0
	<i>Set</i> →	Sample Period	Sample Period	Sample Period	Source state
	<i>Set</i> →	Source state	Source state	Switchpoint0	Switchpoint1
	<i>Set</i> →	Sink state	Switchpoint1	Source state	Sink state
	<i>Set</i> →	n/a	Sink state	Sink state	n/a

“V” Menu Output Configuration Setup

Use the V menu to set up the 4-20 mA analog outputs (including NAMUR configuration) and source/sink (pulse) outputs.



Note: The display comes up to the last setting saved and stays for 2 seconds. If N or [ENTER] is entered, the menu proceeds to the next item in the sequence (refer to “Table 3. V Menu – Output Configuration Setup” on page 8). If Y is entered, the display moves to the selection options and/or asks for confirmation. If you miss the option, select [Enter] repeatedly to loop around.

<p>Analog Out Output Mode Selected</p> <p>4-20 mA #1: Flow 4-20 mA #2: Temp</p> <p>Change? (Y/N)></p> <p>4-20 mA #1: Flow 4-20 mA #2: Temp Enter 1 to make the selection __</p> <p>4-20 mA #1: Flow 4-20 mA #2: Flow Enter 2 to make the selection __</p> <p>4-20 mA #1: Temp 4-20 mA #2: Flow Enter 3 to make the selection __</p> <p>4-20 mA #1: Temp 4-20 mA #2: Temp Enter 4 to make the selection __</p>	<p>NAMUR Mode Selected NAMUR: Off</p> <p>Change? (Y/N)></p> <p>NAMUR: Off Enter 1 to make the selection # __</p> <p>NAMUR: Low Enter 2 to make the selection # __</p> <p>NAMUR: High Enter 3 to make the selection # __</p> <p>Pulse Out Pulse Out Selected</p> <p>Source: Pulse Sink: Pulse</p> <p>Change? (Y/N)></p> <p>Source: Pulse Sink: Pulse Enter 1 to make the selection # __</p> <p>Source: Pulse Sink: Alarm1 Enter 2 to make the selection # __</p>	<p>Source: Alarm0 Sink: Pulse Enter 3 to make the selection # __</p> <p>Source: Alarm0 Sink: Alarm1 Enter 4 to make the selection # __</p> <p>PFactor: 1.000 Change? (Y/N)> if yes Enter new factor: ____</p> <p>Sample Period: 1 second Change? (Y/N)> if yes Enter new Sample Period: ____</p> <p><i>If alarm is a selected output</i> Set point1: 000 Set points are in the same units as the flow or temp.</p> <p>Change? (Y/N)> if yes Enter new set point: ____ Resume normal operation</p> <p>Source state: High to Low</p> <p>Change to Low to High?></p>
---	--	--

Example: COMMAND V (Reference Table 3)

Case: 4-20 mA #1 = Flow, 4-20 mA #2 = Temperature, NAMUR = Low, Source Out = Pulse, Sink = Alarm1

Pressing [V] [ENTER] will display

“Output Mode Selected”

The last saved mode of the next menu item displays:

“4-20 mA #1 = Flow”

“ 4-20 mA #2 = Temp”

...followed by the prompt:

“Change? (Y/N)”

Press [ENTER] (no change).

The last saved mode of the next menu item displays:

“NAMUR: Off”

...followed by the prompt:

“Change? (Y/N)”

Select Y [Enter].

The display reads,

“NAMUR: Off”

...followed by the prompt:

“Enter 1 to make the selection #.”

Select [ENTER].

Bypassing “1” the next display reads,

“NAMUR: Low”

...followed by the prompt:

“Enter 2 to make the selection #.”

Select 2 and [ENTER].

“2” sets the new NAMUR configuration.

The last saved mode of the next menu item displays:

“Source: Pulse”

“Sink: Pulse”

...followed by the prompt:

“Change? (Y/N)”

Select Y [Enter].

The display reads,

“Source: Pulse”

...followed by the prompt:

“Enter 1 to make the selection #.”

Select [ENTER].

Bypassing “1” the next display reads,

“Source: Pulse”

...followed by the prompt:

“Enter 2 to make the selection #.”

Select 2 and [ENTER].

“2” sets the new source/sink configuration.

The last saved mode of the next menu item displays:

“PFactor: 1.000”

...followed by the prompt:

“Change? (Y/N)>”

Respond with “Y” to enter a factor anywhere from 0.001 to 1000. A pulse factor of 1.000 outputs 1 pulse per unit of flow. If no change, select N and/or [ENTER] to continue.

Troubleshooting

Application Verification

After verifying that the flow meter is functioning, review the application parameters as shown below to verify the calibration matches the process media.

Equipment Needed

Flow Instrument Calibration Data
Process Parameters and Limits

Check Serial Numbers

Verify that the serial number of the flow element and the flow transmitter electronics are the same. The flow element and the flow transmitter are a matched set and cannot be operated independently of each other.

Check the Instrument Installation

Verify correct mechanical and electrical installation. Verify the flow element is mounted at least 20 diameters downstream and 10 diameters upstream from any bends or interference in the process pipe or duct.

Check for Moisture

Check for moisture on the flow transmitter. Moisture may cause intermittent operation. Check for moisture on the flow element. If a component of the process media is near its saturation temperature it may condense on the flow element. Place the flow element where the process media is well above the saturation temperature of any of the process gases.

Check Application Design Requirements

Application design problems may occur with first time application instruments, although the design should also be checked on instruments that have been in operation for some time. If the application design does not match field conditions, errors occur.

1. Review the application design with plant operation personnel and plant engineers.
2. Ensure that plant equipment such as pressure and temperature instruments conform to the actual conditions.
3. Verify operating temperature, operating pressure, line size, and gas medium.

Verify Standard Versus Actual Process Conditions

The flow meter measures the mass flow rate. The mass flow rate is the mass of the gas flowing through a pipe per time. Other flow meters, such as an orifice plate or a pitot tube, measure the volumetric flow rate. The volumetric flow rate is the volume of gas per time. If the readings displayed do not agree with another instrument, some calculations may be necessary before comparing them. To calculate the mass flow rate, the volumetric flow rate, and the pressure and temperature, the point of measurement must be known. Use the following equation to calculate the mass flow rate (Standard Volumetric Flow rate) for the other instrument:

Equation:

$$Q_s = Q_A \times \frac{P_A}{T_A} \times \frac{T_s}{P_s}$$

(Metric: Where bar(a) and °K are used for pressure and temperature.)

Where:

Q_A = Volumetric Flow Q_s = Standard Volumetric Flow
 P_A = Actual Pressure T_A = Actual Temperature
 P_s = Standard Pressure T_s = Standard Temperature
 PSIA and °R are used for pressure and temperature units.

Example:

Q_A = 1212.7 ACFM Q_s = 1485 SCFM
 P_A = 19.7 PSIA T_A = 120 °F (580 °R)
 P_s = 14.7 PSIA T_s = 70 °F (530 °R)

(Metric: P_s = 1.01325 bar(a)
 T_s = 21.1°C (294.1K))

$$\left(\frac{1212.7 \text{ ACFM}}{1} \right) \left(\frac{19.7 \text{ PSIA}}{580 \text{ °R}} \right) \left(\frac{530 \text{ °R}}{14.7 \text{ PSIA}} \right) = 1485 \text{ SCFM}$$

Calibration Parameters Verification

The instrument uses a set of predetermined calibration parameters to process flow signals. Most of these parameters should not change. A data package shipped with the instrument (typically on a CD-ROM) contains the *ST75/ST75V Delta R Data Sheet*. This contains the calibration parameters stored in the flow transmitter at the factory. To verify that these parameters have not changed, complete the following:

1. Identify the appropriate Delta R data sheets by serial number of the instrument.
2. Press [D] [ENTER] to examine each of the parameters. The [ENTER] key allows scrolling one message at a time. Use Table 4 below to record actual instrument parameters. Compare with the Delta R data sheet's ST75/ST75V parameters.

Table 4. Diagnostic Test Sequence on Display

S/W Version:		dR Min:		T SpanIDA C 0:	
Flow Factor:		dR Max:		T ZeroIDA C 0:	
Cmin Flow:		Cal Ref:		T SpanIDA C 1:	
Cmax Flow:		Tcslp:		T ZeroIDA C 1:	
Eng Units :		Tcslp 0:		State 0:	
Line Size 0:		Tcslp 2:		Switch Pt 0:	
Line Size 1:		Tot Menu:		State 1:	
Cmin Temp :		Tot Flag:		Switch Pt 1:	
Cmax Temp :		Totalizer:		K factor 1:	
Min Flow:		Rollover Cnt:		K factor 2:	
Max Flow:		Fix Pt Flag:		K factor 3:	
Density:		Pulse Factor:		K factor 4:	
*C1 [1]:		Pulse Out:		I factor:	
*C1 [2]:		Hours:		Temp Flag:	
*C1 [3]:		Sample Period:		Out Mode:	
*C1 [4]:		dR Slope :		Namurmode:	
*C1 [5]:		dR Off Set :		Boxcar Max:	
Break Pt:		Refr Slope:		RTD-SLP-385:	
*C2 [1]:		Refr Off Set:		% of Range:	
*C2 [2]:		SpanIDAC 0:		User Name:	
*C2 [3]:		ZeroIDAC 0:		Shop Order #:	
*C2 [4]:		SpanIDAC 1:		Serial No.:	
*C2 [5]:		ZeroIDAC 1:		Mode l#:	

An issue may exist if parameters with an asterisk (*) have changed. Contact Customer Service if this is the case. If the parameters have not changed, continue with the next section.

Hardware Verification

Equipment Required:

- Digital Multimeter
- Screwdriver

The ST75/ST75V flow meter is made up of these basic components:

- Sensor element.
- Customer interface circuit board
- Control circuit assembly circuit board module.
- Electronics enclosure.

Step 1

Verify fuse (F1) located on the customer interface circuit board is in normal working condition.

Remove power from the instrument. Open the electronics enclosure exposing the customer interface circuit board. This circuit board is located under the shorter enclosure lid along with all of the power and input/output connections. Unscrew the clear cover on the fuse and pull the fuse out of the fuse holder. Check the fuse for continuity. If fuse reads open, replace with equivalent component (FCI part no. 019933-01), Wickmann Inc. Series 374, 1.6 A (amp code 1160), package 0410 (short radial leads).

AC power customer interface circuit board shown. Fuse (F1) on DC power customer interface circuit board located in similar position.

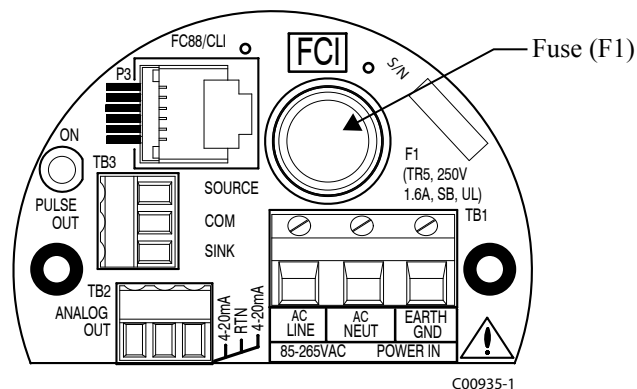

Step 2

Verify interconnecting cable from the customer interface board and the control circuit board assembly module are correctly seated into the appropriate header.

Remove power from the instrument. Open the electronics enclosure exposing the customer interface circuit board. This circuit board is located under the shorter enclosure lid along with all of the power and input/output connections. Remove the 2 screws securing the interface circuit board to the electronics enclosure. Carefully lift the interface board out of the housing exposing the interconnecting cable between the interface board and the control circuit assembly. Verify cable is seated firmly at both ends of the cable header.

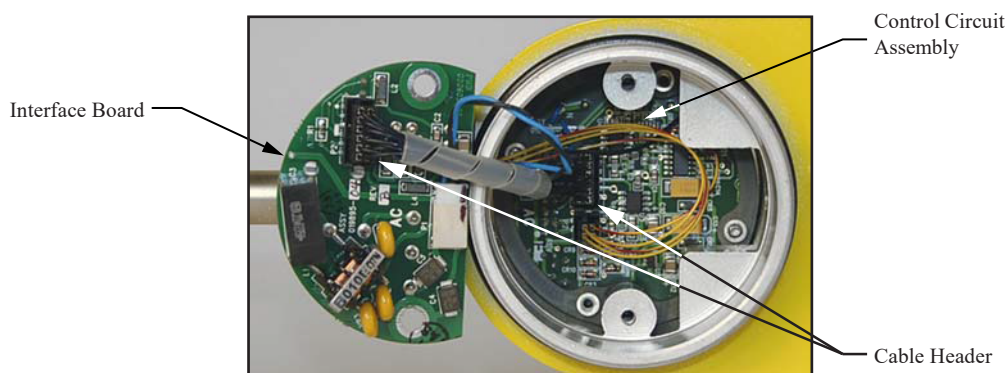

Step 3

Verify sensor element continuity and resistance.

Remove sensor element cable from the bottom of the control circuit assembly. Note that two of the wires have a red stripe and are located closest to the interconnecting cable header. Using an ohmmeter verify that resistance between the 2 red striped wires is approximately 1100 ohms \pm 20 ohms. This resistance is temperature dependent. The resistance at 70 degrees F is about 1082 ohms. Verify the resistance between the 2 natural colored wires are approximately the same.

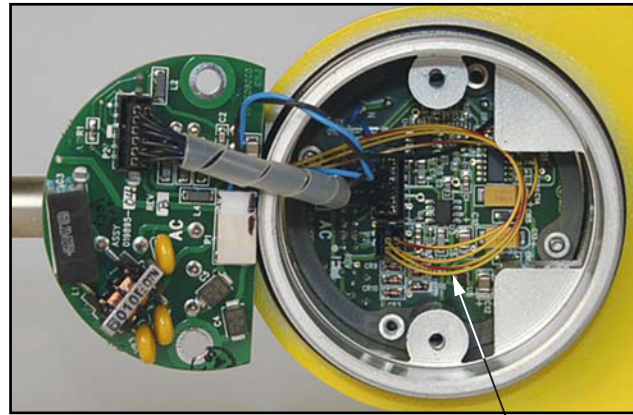

Sensor Element
Cable

FCI provides full in-house technical support. Additional technical representation is also provided by FCI field representatives. Before contacting a field or in-house representative, please perform the troubleshooting techniques outlined in this document. If problems persist, contact the FCI Customer Service department at 1-800-854-1993 or 1-760-744-6950.

Contact FCI to obtain a Return Authorization before returning the instrument. The form contains a declaration of decontamination cleaning information that the instrument must comply with before it is shipped to FCI.

Transmitter Circuit Calibration Check (Delta R Verification)

References

- Delta ‘R’ Data Sheet

Equipment

- FC88 Communicator or equivalent.
- DVM
- Delta R data sheet - Match by serial numbers
- 2 ea. precision decade resistance boxes, 0.1% (Largest steps: 1k ohm, smallest steps 0.01 ohms)
- Small flat blade screwdriver, 3/32 inches wide blade
- FCI normalization cable, FCI part number 006407

Procedure

i Note: Thirty (30) second warm-up required before calibration check.

1. Verify all “D” mode calibration parameters are correct according to the meter’s Delta R data sheet before starting verification.
2. Turn power OFF.
3. Mark all sensor element wires connected to the circuit board for easier reconnection to the proper terminals. Disconnect the wires.
4. Connect the resistance decade box to the electronics as per the appropriate wiring diagram for the ST75/ST75V.

i Note: Interconnecting wiring (resistance decade box to electronics) must be same gauge and length to avoid any inaccuracies in the Delta R verification caused by unequal wire lengths and/or wire gauges.

5. Set both decade boxes for the nominal resistance value (1000 ohms) ±0.01%
6. Connect DVM to the meter’s output termination and monitor the meter output.
7. Turn the power ON and allow the instrument 5 minutes to stabilize.
8. With the FC88 connected, Press [T] [Enter] to view the Normal Operating Mode.
9. Adjust the Active decade box (Reference decade box remains fixed @ 1000 ohms) to achieve the appropriate Delta R for the displayed flow value and output, noted on the meter’s Delta R data sheet.
10. Note the [C] mode and verify the meter’s displayed TCDR and REFR values corresponding to the displayed flow rate as per the meter’s Delta R data sheet.
11. Return to normal mode operation ([T] mode).

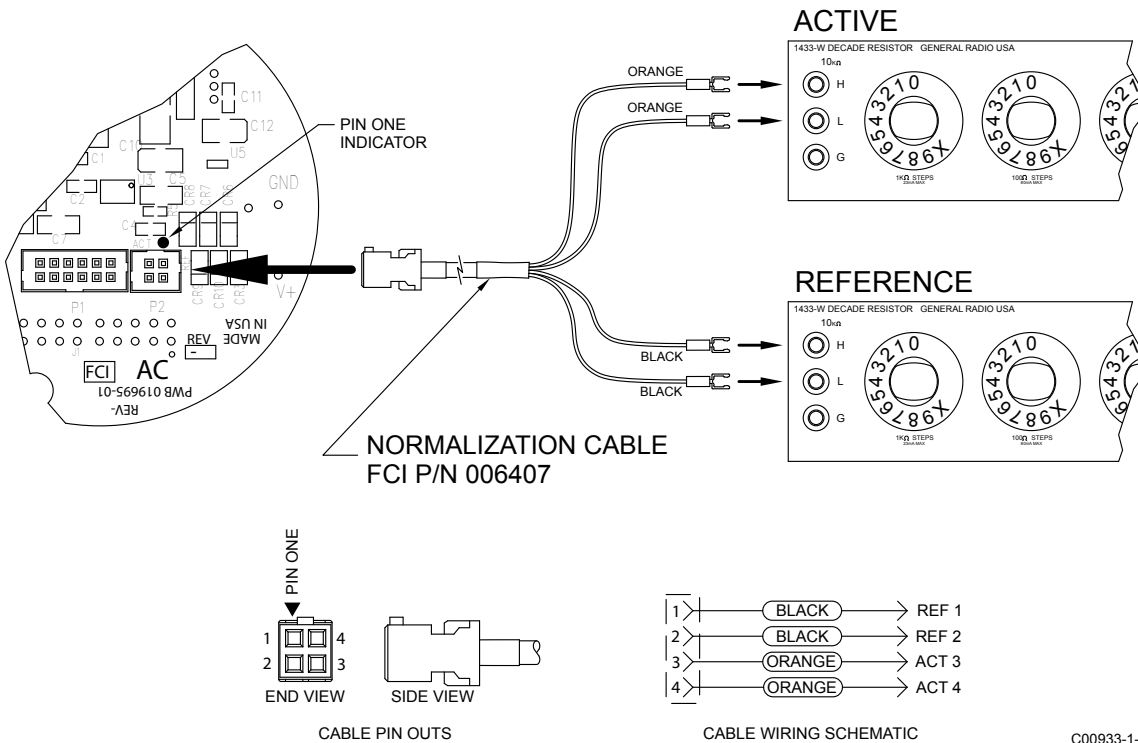

C00933-1-2

INTENTIONALLY LEFT BLANK

Appendix A - Approval Information

EU Information



EU DECLARATION OF CONFORMITY ST51 SERIES

We, *Fluid Components International LLC*, located at 1755 La Costa Meadows Drive, San Marcos, California 92078-5115 USA, declare under our sole responsibility that the **ST51 Flowmeter Product Family** (ST51, ST75, ST75V, ST51A, ST75A, ST75AV), to which this declaration relates, are in conformity with the following standards and Directives.

Directive 2014/34/EU ATEX

Certified by FM Approvals Europe LTD, (2809): One George Quay Plaza, D02 E440, Dublin, Ireland

EC-Type Examination Certificate:

FM16ATEX0008X satisfies EN 60079-0:2012/A11:2013, EN 60079-1:2014, EN 60079-31:2014 and EN 60529:1991 +A2:2013 requirements for use in hazardous areas.

Hazardous Areas Approval FM16ATEX0008X
 II 2 G Ex db IIC T6...T1 Gb
 II 2 D Ex tb IIIC T85°C...T300°C Db; IP66/IP67
 Ta = -40°C to +65°C

Directive 2014/30/EU EMC

Immunity specification: EN 61000-6-2: 2005
Emissions specification: EN 61000-6-4: 2007, +A1:2011

Directive 2014/35/EU Low Voltage

Electrical Safety Specification: EN 61010-1: 2010 +C1: 2011 +C2: 2013

Directive 2014/68/EU Pressure Equipment (PED)

The ST51/ST51A (Insertion Style) models do not have a pressure bearing housing and are therefore not considered as pressure equipment by themselves according to article 2, paragraph 5.
 The ST75/ST75A, ST75V/ST75AV (In-line Style) models are in conformity with Sound Engineering Practices as defined in the Pressure Equipment Directive (PED) 2014/68/EU article 4, paragraph 3.

RoHS – Declaration of Compliance

The ST51 Product Family is in conformity with Directive 2011/65/EU of the European Parliament and of the council of 8 June 2011 on the restriction of the use of Certain Hazardous substances in electrical and electronic equipment and its amendment (EU) 2015/863 of 31 March 2015.

Issued at San Marcos, California USA
 July, 2021

Fouad
 cfo@fluidcomponents.com
 email: fchirar@fluidcomponents.com, cfo@us
 20210720 09:07:37 -07'00'

Fouad Chirar, Qualification Engineer

Flow/Liquid Level/Temperature Instrumentation

Visit FCI on the Worldwide Web: www.fluidcomponents.com

1755 La Costa Meadows Drive, San Marcos, California 92078 USA 760-744-6950 • 800-854-1993 • 760-736-6250
 European Office: Persephonestraat 3-01 5047 TTilburg – The Netherlands – Phone 31-13-5159989 • Fax 31-13-5799036

Doc no. 23EN000019H

Specific Conditions of Use per FM16ATEX0008X

1. The ambient temperature range and applicable temperature class of the sensor probe is based on the maximum process temperature for the particular application as follows; T6...T1 for T_{ambient} of -40 °C to +65 and T_{process} of -40 °C to +260 °C. Probe assembly design temperatures are part number dependent. Low temperature models have design temperatures from -40°C to +121°C. Medium temperature models have design temperatures from -40 °C to +260 °C.
2. Process Temperature: Maximum process temperature range is -40 °C to +260 °C. Process temperature varies for flow element installed. The relationship between the temperature class, the maximum surface temperature and the process temperature is as follows:
Sensing Element:
T6 / T85°C for a process temperature range of -40 °C to +39 °C.
T5 / T100°C for a process temperature range of -40 °C to +54 °C.
T4 / T135°C for a process temperature range of -40 °C to +89 °C.
T3 / T200°C for a process temperature range of -40 °C to +154 °C.
T2 / T300°C for a process temperature range of -40 °C to +177 °C.
T1 for a process temperature range of -40 °C to +260 °C.
3. Consult the manufacturer if dimensional information on the flameproof joints is necessary.
4. The painted surfaces of the mass flow meter may store electrostatic charge and become a source of ignition in applications with a low relative humidity <~30% relative humidity where the painted surface is relatively free of surface contamination such as dirt, dust, or oil. Guidance on protection against the risk of ignition due to electrostatic discharge can be found in IEC TR60079-32 (in preparation). Cleaning of the painted/unpainted surface should only be done with a damp cloth.
5. The probe when remotely located from the enclosure has flying lead conductors that requires the remote probe to be connected to a suitably certified Ex d or Ex e terminal box for connecting to the external supply circuit.
6. Customer to supply wire rated 10 °C minimum above maximum ambient temperature of installation location to a suitably certified Ex d or Ex e terminal box.

Safety Instructions for the use of the ST51/75 flow meter in Hazardous Areas

Approval FM16ATEX0008X/IECEX FMG 16.0009X for:

II 2 G Ex db IIC T6...T1 Gb

II 2 D Ex tb IIIC T85°C...T300°C Db; IP66/IP67

The ST51/75 series consist of a sensing element and associated integral or remote mounted electronics mounted in a type "d" flameproof enclosure.

Relation between ambient temperature, process temperature, and temperature class is as follows:

Ambient temperature range (Ta):	T6/T85°C for : -40°C <Ta< + 65°C
Process temperature range (Tp):	T6 / T85°C: -40°C < Tp < +39°C
	T5 / T100°C: -40°C <Tp < +54°C
	T4 / T135°C: -40°C < Tp < +89°C
	T3 / T200°C: -40°C < Tp < +154°C
	T2 / T300°C: -40°C < Tp < +177°C
	T1: -40°C < Tp < +260°C

Electrical data: Power supply: 85 to 265 VAC, 50/60 Hz, 10 W; 18–36 VDC, 9.6 W.

Dansk	Sikkerhedsforskrifter	Italiano	Normative di sicurezza
Deutsch	Sicherheitshinweise	Nederlands	Veiligheidsinstructies
English	Safety instructions	Português	Normas de segurança
Ελληνική	Υποδείξεις ασφαλείας	Español	Instrucciones de seguridad
Suomi	Turvallisuusohjeet	Svenska	Säkerhetsanvisningar
Français	Consignes de sécurité		



Dansk – Sikkerhedsforskrifter

Disse sikkerhedsforskrifter gælder for Fluid Components, ST51/75 EF-typeafprøvningsattest-nr. FM16ATEX0008X/IECEX FMG 16.0009X attestens nummer på typeskiltet) er egnet til at blive benyttet i eksplosiv atmosfære kategori II 2 GD.

- 1) Ex-anlæg skal principielt opstilles af specialiseret personale.
- 2) ST51/75 skal jordforbindes.
- 3) Klemmerne og elektronikken er monteret i et hus, som er beskyttet af en eksplosionssikker kapsling med følgende noter:
 - Gevindspalten mellem huset og låget er på en sådan måde, at ild ikke kan brede sig inden i det.
 - Ex-„d“ tilslutningshuset er forsynet med et ½" NPT og/eller M20x1.5 gevind for montering af en Ex-„d“ kabelindføring, der er atterteret iht IEC/EN 60079-1.
 - Det er vigtigt at sørge for, at forsyningsledningen er uden spænding eller eksplosiv atmosfære ikke er til stede, før låget åbnes og når låget er åbent på „d“ huset (f.eks. ved tilslutning eller servicearbejde).
 - Låget på „d“ huset skal være skruet helt ind, når apparatet er i brug. Det skal sikres ved at dreje en af låseskruerne på låget ud.



Deutsch – Sicherheitshinweise

Diese Sicherheitshinweise gelten für die Fluid Components, ST51/75 flow meter gemäß der EG-Baumusterprüfbescheinigung Nr. FM16ATEX0008X/IECEX FMG 16.0009X (Bescheinigungsnummer auf dem Typschild) der Kategorie II 2 GD.

- 1) Die Errichtung von Ex-Anlagen muss grundsätzlich durch Fachpersonal vorgenommen werden.
- 2) Der ST51/75 muß geerdet werden.
- 3) Die Klemmen und Elektronik sind in einem Gehäuse in der Zündschutzart druckfeste Kapselung („d“) eingebaut.
 - Der Gewindespalt zwischen dem Gehäuse und dem Deckel ist ein zünddurchschlagsicherer Spalt.
 - Das Ex-„d“ Anschlussgehäuse besitzt ein 1/2" NPT und/oder M20x1.5 Gewinde für den Einbau einer nach IEC/EN 60079-1 bescheinigten Ex-„d“ Kabeleinführung.
 - Es ist sicherzustellen, dass vor dem Öffnen und bei geöffnetem Deckel des „d“ Gehäuses (z.B. bei Anschluss oder Service- Arbeiten) entweder die Versorgungsleitung spannungsfrei oder keine explosionsfähige Atmosphäre vorhanden ist.
 - Der Deckel des „d“ Gehäuses muss im Betrieb bis zum Anschlag hineingedreht sein. Er ist durch eine der Deckelarretierungsschrauben zu sichern.

(GB) (IRL) English – Safety instructions

These safety instructions are valid for the Fluid Components, ST51/75 flow meter to the EC type approval certificate no FM16ATEX0008X/IECEX FMG 16.0009X (certificate number on the type label) for use in potentially explosive atmospheres in Category II 2 GD.

- 1) The installation of Ex-instruments must be made by trained personnel.
- 2) The ST51/75 must be grounded.
- 3) The terminals and electronics are installed in a flame proof and pressure-tight housing with following notes:
 - The gap between the housing and cover is an ignition-proof gap.
 - The Ex-"d" housing connection has a ½" NPT and/or M20x1.5 cable entry for mounting an Ex-d cable entry certified according to IEC/EN 60079-1.
 - Make sure that before opening the cover of the Ex"d" housing, the power supply is disconnected or there is no explosive atmosphere present (e.g. during connection or service work).
 - During normal operation: The cover of the "d" housing must be screwed in completely and locked by tightening one of the cover locking screws.

(GR) Ελληνική – Υποδείξεις ασφαλείας

Αυτές οι οδηγίες ασφαλείας ισχύουν για τα Ροόμετρα της Fluid Components τύπου ST51/75 που φέρουν Πιστοποιητικό Εγκρίσεως Ευρωπαϊκής Ένωσης, με αριθμό πιστοποίησης FM16ATEX0008X/IECEX FMG 16.0009X (αριθμός πιστοποίησης βρίσκεται πάνω στην ετικέτα τύπου του οργάνου) για χρήση σε εκρηκτικές ατμόσφαιρες της κατηγορίας II 2 GD.

- 1) Η εγκατάσταση των οργάνων με αντικρηκτική προστασία πρέπει να γίνει από εξειδικευμένο προσωπικό.
- 2) Το όργανο τύπου ST51/75 πρέπει να είναι γειωμένο.
- 3) Τα τερματικά ηλεκτρικών συνδέσεων (κλέμες) και τα ηλεκτρονικά κυκλώματα είναι εγκατεστημένα σε περίβλημα αντικρηκτικό και αεροστεγές σύμφωνα με τις ακόλουθες παρατηρήσεις:
 - Το κενό ανάμεσα στο περίβλημα και στο κάλυμμα είναι τέτοιο που αποτρέπει την διάδοση σπινθήρα.
 - Το "Ex-d" αντικρηκτικό περίβλημα, έχει ανοίγματα εισόδου καλωδίου με διάμετρο ½" NPT ή/και M20x1.5, κατάλληλα για τοποθέτηση υποδοχής αντικρηκτικού καλωδίου πιστοποιημένης κατά IEC/EN 60079-1.
 - Βεβαιωθείτε ότι πριν το άνοιγμα καλύμματος του του "Ex-d" αντικρηκτικού περιβλήματος, η τάση τροφοδοσίας είναι αποσυνδεδεμένη ή ότι δεν υφίσταται στη περιοχή εκρηκτική ατμόσφαιρα (π.χ. κατά τη διάρκεια της σύνδεσης ή εργασιών συντήρησης).
 - Κατά τη διάρκεια ομαλής λειτουργίας: Το κάλυμα του "d" καλύμματος αντικρηκτικού περιβλήματος πρέπει να είναι εντελώς βιδωμένο και ασφαλισμένο, σφίγγοντας μία από τις βίδες ασφαλείας του περιβλήματος.

(FIN) Suomi – Turvallisuusohjeet

Nämä turvallisuusohjeet koskevat Fluid Components, ST51/75 EY-tyyppitarkastustodistuksen nro. FM16ATEX0008X/IECEX FMG 16.0009X (todistuksen numero näkyy tyyppikilvestä) käytettäessä räjähdysvaarallisissa tiloissa luokassa II 2GD.

- 1) Ex-laitteet on aina asennettava ammattihenkilökunnan toimesta.
- 2) ST51/75 on maadoitettava.
- 3) Syöttöjännitteen kytkemisessä tarvittavat liittimet ja elektroniikka on asennettu koteloon jonka rakenne kestää räjähdyspaineen seuraavin lisäyksin :
 - Kotelon ja kannen välissä on räjähdyspurkausväli.
 - Ex-d liittämätelossa on ½" NPT ja/tai M20x1.5 kierre IEC/EN 60079-1 mukaisen Ex-d kaapeliläpiviennin asennusta varten.
 - Kun "d"-kotelon kansi avataan (esim. liitännän tai huollon yhteydessä), on varmistettava, että joko syöttöjohto on jännitteetön tai ympäristössä ei ole räjähtäviä aineita.
 - "d" -kotelon kansi on kierrettävä aivan kiinni käytön yhteydessä ja on varmistettava kiertämällä yksi kannen lukitusruuveista kiinni.

(F) (B) (L) Français – Consignes de sécurité

Ces consignes de sécurité sont valables pour le modèle ST51/75 de la société Fluid Components (FCI) conforme au certificat d'épreuves de type FM16ATEX0008X/IECEX FMG 16.0009X (numéro du certificat sur l'étiquette signalétique) conçu pour les applications dans lesquelles un matériel de la catégorie II2GD est nécessaire.

- 1) Seul un personnel spécialisé et qualifié est autorisé à installer le matériel Ex.
- 2) Les ST51/75 doivent être reliés à la terre.
- 3) Les bornes pour le branchement de la tension d'alimentation et l'électronique sont logées dans un boîtier à enveloppe antidéflagrante avec les notes suivantes :
 - Le volume entre le boîtier et le couvercle est protégé en cas d'amorçage.
 - Le boîtier de raccordement Ex-d dispose d'un filetage ½" NPT et/ou M20x1.5 pour le montage d'un presse-étoupe Ex-d certifié selon la IEC/EN 60079-1.
 - Avant d'ouvrir le couvercle du boîtier « d » et pendant toute la durée où il le restera (pour des travaux de raccordement, d'entretien ou de dépannage par exemple), il faut veiller à ce que la ligne d'alimentation soit hors tension ou à ce qu'il n'y ait pas d'atmosphère explosive.
 - Pendant le fonctionnement de l'appareil, le couvercle du boîtier « d » doit être vissé et serré jusqu'en butée. La bonne fixation du couvercle doit être assurée en serrant une des vis d'arrêt du couvercle.

① Italiano – Normative di sicurezza

Queste normative di sicurezza si riferiscono ai Fluid Components, ST51/75 secondo il certificato CE di prova di omologazione n° FM16ATEX0008X/IECEX FMG 16.0009X (numero del certificato sulla targhetta d'identificazione) sono idonei all'impiego in atmosfere esplosive applicazioni che richiedono apparecchiature elettriche della Categoria II 2 GD.

1) L'installazione di sistemi Ex deve essere eseguita esclusivamente da personale specializzato.

2) I ST51/75 devono essere collegati a terra.

3) I morsetti per il collegamento e l'elettronica sono incorporati in una custodia a prova di esplosione („d“) con le seguenti note:

- La sicurezza si ottiene grazie ai cosiddetti „interstizi sperimentali massimi“, attraverso i quali una eventuale accensione all'interno della custodia non può propagarsi all'esterno oraggiungere altre parti dell'impianto.
- La scatola di collegamento Ex-d ha una filettatura ½" NPT e/o M20x1.5 per il montaggio di un passacavo omologato Ex-d secondo IEC/EN 60079-1.
- Prima di aprire il coperchio della custodia „d“ (per es. durante operazioni di collegamento o di manutenzione) accertarsi che l'apparecchio sia disinserito o che non si trovi in presenza di atmosfere esplosive.
- Avvitare il coperchio della custodia „d“ fino all'arresto. Per impedire lo svitamento del coperchio é possibile allentare una delle 2 viti esagonali poste sul corpo della custodia, incastrandola nella sagoma del coperchio.

ⓃⓅ Nederlands – Veiligheidsinstructies

Deze veiligheidsinstructies gelden voor de Fluid Components, ST51/75 overeenkomstig de EG-typeverklaring nr. FM16ATEX0008X/IECEX FMG 16.0009X (nummer van de verklaring op het typeplaatje) voor gebruik in een explosieve atmosfeer volgens Categorie II 2GD.

1) Installatie van Ex-instrumenten dient altijd te geschieden door geschoold personeel.

2) De ST51/75 moet geaard worden.

3) De aansluitklemmen en de electronika zijn ingebouwd in een drukvaste behuizing met de volgende opmerkingen:

- De schroefdraadspleet tussen de behuizing en de deksel is een ontstekingsdoorslagveilige spleet.
- De Ex-d aansluitbehuizing heeft een ½" NPT of een M20x1.5 schroefdraad voor aansluiting van een volgens IEC/EN 60079-1 goedgekeurde Ex- 'd' kabelinvoer.
- Er moet worden veilig gesteld dat vóór het openen bij een geopende deksel van de 'd' behuizing (bijv. bij aansluit- of servicewerkzaamheden) hetzij de voedingsleiding spanningsvrij is, hetzij geen explosieve atmosfeer aanwezig is.
- De deksel van de 'd' behuizing moet tijdens bedrijf tot aan de aanslag erin geschroefd zijn. Hij moet door het eruit draaien van een van de dekselborgschroeven worden geborgd.

Ⓟ Português – Normas de segurança

Estas normas de segurança são válidas para os Fluid Components, ST51/75 conforme o certificado de teste de modelo N.º FM16ATEX0008X/IECEX FMG 16.0009X (número do certificado na plaqueta com os dados do equipamento) são apropriados para utilização em atmosferas explosivas categoria II 2 GD.

1) A instalação de equipamentos em zonas sujeitas a explosão deve, por princípio, ser executada por técnicos qualificados.

2) Os ST51/75 Flexmasster precisam ser ligados à terra.

3) Os terminais e a electrónica para a conexão da tensão de alimentação estão instalados num envólucro com protecção contra ignição á prova de sobrepressão com as seguintes notas:

- A fenda entre o envólucro e a tampa deve ser á prova de passagem de centelha.
- O envólucro de conexão Ex-“d” possui uma rosca ½" NPT e/ou M20x1.5 para a entrada de cabos Ex-“d” certificado conforme a norma IEC/EN 60079-1.
- Deve-se assegurar que, antes de abrir a tampa do armário „d“ (por exemplo, ao efectuar a conexão ou durante trabalhos de manutenção), o cabo de alimentação esteja sem tensão ou que a atmosfera não seja explosiva.
- Durante a operação, a tampa do envólucro „d“ deve estar aparafusada até o encosto. A tampa deve ser bloqueada, por um dos parafusos de fixação.

Ⓜ Español – Instrucciones de seguridad

Estas indicaciones de seguridad son de aplicación para el modelo ST51/75 de Fluid Components, según la certificación CE de modelo N° FM16ATEX0008X/IECEX FMG 16.0009X para aplicaciones en atmósferas potencialmente explosivas según la categoría II 2 GD (el número decertificación se indica sobre la placa informativa del equipo).

1) La instalación de equipos Ex tiene que ser realizada por personal especializado.

2) Los ST51/75 tienen que ser conectados a tierra.

3) Los bornes de conexión y la unidad electrónica están montados dentro de una caja con protección antideflagrante y resistente a presión, considerándose los siguientes puntos:

- La holgura entre la rosca de la tapa y la propia de la caja está diseñada a prueba contra ignición.
- La caja tiene conexiones eléctricas para entrada de cables con rosca ½" NPT y/o M20x1.5, donde deberán conectarse prensaestopas certificados Exd según IEC/EN60079-1.
- Antes de la apertura de la tapa de la caja «Exd» (p. ej. durante los trabajos de conexionado o de puesta en marcha) hay que asegurar que el equipo se halle sin tensión o que no exista presencia de atmósfera explosiva.
- Durante el funcionamiento normal: la tapa de la caja antideflagrante tiene que estar cerrada, roscada hasta el tope, debiéndose asegurar apretando los tornillos de bloqueo.



Svenska – Säkerhetsanvisningar

Säkerhetsanvisningarna gäller för Fluid Components, Flödesmätare typ ST51/75 enligt EG-typkontrollintyg nr FM16ATEX0008X/IECEX FMG 16.0009X (intygsnumret återfinns på typskylten) är lämpad för användning i explosiv gasblandning i kategori II 2 GD.

1) Installation av Ex- klassade instrument måste alltid utföras av fackpersonal.

2) ST51/75 måste jordas.

3) Anslutningsklämmorna och elektroniken är inbyggda i en explosions och trycktät kapsling med följande kommentar:

- Spalten mellan kapslingen och lockets gänga är flamsäker.
- Ex-d kapslingen har en 1/2" NPT och / eller M20x1.5 gänga för montering av en IEC/EN 60079-1 typkontrollerad Ex- „d“ kabel förskruvning.
- När Ex- „d“-kapslingens lock är öppet (t.ex. vid inkoppling - eller servicearbeten) ska man se till att enheten är spänningslös eller att ingen explosiv gasblandning förekommer.
- Under drift måste Ex - d“-kapslingens lock vara iskruvad till anslaget. För att säkra locket skruvar man i en av lockets insex låsskruvar.

Appendix B - List Commands

Table 5. ST75/ST75V List of Single Letter Commands

COMMAND MNEMONIC	COMMAND FUNCTION	COMMAND DESCRIPTION
A	R	AvgDelta_r, AvgRef
B	R	Delta_r, Ref_r
C	R	Tcdelta_r, Ref_r
D	R	Diagnostics
F	R/W	Kfactors
G	R/W	Clear FlashEE, Boxcar Count, ADC to Ohms Cal
K	R/W	Cal Parameters
L	R/W	Output Cal
N	W	Warm Restart
R	W	Factory Restore
S	R/W	Totalizer Menu On/Off
T	R	Normal Mode
V	R/W	Output Config
W	R/W	Totalizer
Y	W	Command Line Interface
Z	W	Flow units, Pipe Size, and LCD Scaling

Table 6. ST75/ST75V List of CLI Commands

COMMAND MNEMONIC	COMMAND FUNCTION	COMMAND DESCRIPTION	DATA TYPE
BK	R/W	Break Point	Float
BM	R/W	Boxcar Filter Max	Integer
CM	R/W	Cminflow	Float
CR	R/W	Calibration Ref	Float
CX	R/W	Cmaxflow	Float
C1[1-5]	R/W	Coefficients set1	Float
C2[1-5]	R/W	Coefficients set2	Float
DI	R	Diagnostics	Null
DM	R/W	DeltaR Minimum	Float
DN	R/W	Density	Float
DR	R	Delta R	Float
DX	R/W	DeltaR Maximum	Float
DS	R/W	DeltaR Slope	Float
DF	R/W	DeltaR Offset	Float
EU	R/W	Engineering Units	Integer
FF	R/W	Flow Factor	Float
FP	R/W	Fix Point Flag	Integer
F0	R/W	Pulse Out State0	Integer
F1	R/W	Pulse Out State1	Integer
HR	R/W	Tot Dump Hours Cntr	Integer
IF	R/W	I Factor	Float

Table 6. ST75/ST75V List of CLI Commands, Cont.

COMMAND MNEMONIC	COMMAND FUNCTION	COMMAND DESCRIPTION	DATA TYPE
K[1-4]	R/W	K Factors	Float
L0	R/W	Line Size 0	Float
L1	R/W	Line Size 1	Float
MN	R/W	Minflow	Float
MX	R/W	Maxflow	Float
NN	R/W	Namur Mode	Integer
OM	R/W	Outmode	Integer
PF	R/W	Pulse Factor	Float
PL	R/W	Pulse Out	Integer
PS	R/W	Pulse Sample Period	Float
PW	R/W	Pulse Width	Float
P0	R/W	Switch Point0	Integer
P1	R/W	Switch Point1	Integer
RO	R/W	RollOver Cntr	Long
RR	R	Reference R	Float
RS	R/W	RefR Slope	Float
RF	R/W	RefR Offset	Float
SF	R	SFPS Flow	Float
SN	R/W	Serial Number	String (16 chars max.)
SO	R/W	Shop Order Number	String (16 chars max.)
S0	R/W	SpanDAC0 for 4-20mA #1	Integer
S3	R/W	SpanDAC1 for 4-20mA #2	Integer
S2	W	Save FACTORY	N/A
TC	R	TCDeltaR	Float
TD	R/W	Tcslp	Float
TF	R/W	Totalizer OFF/ON Flag	Integer
TM	R/W	Cmintemp	Float
TP	R/W	Totalizer Temperature Flag	Integer
TT	R/W	Totalizer Value	Float
TX	R/W	Cmaxtemp	Float
TZ	R	Temperature	Float
T0	R/W	Tcslp0	Float
T2	R/W	Tcslp2	Float
T3	R/W	TSpanDAC0 for 4-20mA #1	Integer
T7	R/W	TSpanDAC1 for 4-20mA #2	Integer
T5	R/W	TZeroDAC0 for 4-20mA #1	Integer
T8	R/W	TZeroDAC1 for 4-20mA #2	Integer
UF	R	User Flow	Float
UK	R	User FlowK	Float
UN	R/W	User Name	String (16 chars max.)
VN	R	Version Number	String (16 chars max.)
XX	R/W	Test Flow Rate (SFPS)	Float
XY	W	Delete Test Flow Rate	Float
Z0	R/W	ZeroDAC0 for 4-20mA #1	Integer
Z2	R/W	ZeroDAC1 for 4-20mA #2	Integer

Command Line Password: 357



Note: When invoking a Write Function, there must be a space separating the Command characters and the data value. All Read and Write Functions are completed with a <CR>. To exit CLI, press <CR> following the last Command <CR>.

Examples:

RBK<CR>	(Read Breakpoint)
WBK 2222<CR>	(Write Breakpoint 2222)
RC11<CR>	(Read Coefficient C1,1)
WC11 -234.567<CR>	(Write Coefficient C1,1, -234.567)
<CR>	(Leave Command Line Mode)

INTENTIONALLY LEFT BLANK

Appendix C - Drawings

4
3
2
1

NOTICE OF PROPRIETARY RIGHTS

This document contains confidential technical data, including trade secrets and proprietary information which are the property of Fluid Components Intl (FCI). Disclosure of this data to you is expressly conditioned upon your assent that its use is limited to use within your company only (and does not include manufacture or processing uses). Any other use is strictly prohibited without the prior written consent of FCI.

REVISIONS		
REV	DESCRIPTION	DATE
A	MAJOR (SEE DCN)	9/9/08

CONFIG	DIM A TUBE SIZE	DIM B TOP TO FLOW CL	DIM C FLOW CL TO BOTTOM	DIM D TEE LENGTH
ST75-XXXGXX	1/4 INCH TUBING	5.7 MAX [144.8]	.33 [8.38]	2.34 [59.44]
ST75-XXXHXX	1/2 INCH TUBING	6.8 MAX [173.9]	.33 [8.38]	2.81 [71.4]
ST75-XXXJXX	1 INCH TUBING	7.8 MAX [198.1]	.87 [22.10]	3.88 [98.04]

TUBE TEE CONFIGURATION

SPECIFICATIONS:

CUSTOMER: _____

PURCHASE ORDER NO.: _____

CUSTOMER ORDER NO.: _____

WETTED SURFACE MATERIAL: _____

FERRULE TYPE : _____

U LENGTH: _____

SERIAL NO.(S): _____

TAG NO.(S): _____

6. PROCESS PRESSURE: 600 PSIG MAX.

5. SEE INSTRUMENT MANUAL FOR ADDITIONAL INFORMATION AND INSTRUCTION.

4. ALL ORIENTATION AND/OR MOUNTING REFERENCES ARE INDICATED FROM TERMINAL ENCLOSURE END OF SENSING ELEMENT.

3. FOR ELECTRICAL OPTIONS, CONNECTIONS AND TESTS, SEE APPLICABLE WIRING DIAGRAM.

2. DIMENSIONS IN BRACKETS [] ARE IN MILLIMETERS.

1. THIS DRAWING IS A REFERENCE DOCUMENT ONLY.

OUTLINE/INSTALLATION DRAWING

<p>UNLESS OTHERWISE SPECIFIED DIMENSIONS ARE IN INCHES TOLERANCES</p> <table border="1" style="width: 100%; border-collapse: collapse;"> <tr> <th>DECIMALS</th> <th>ANGULAR</th> </tr> <tr> <td>±.01</td> <td>±1/2°</td> </tr> <tr> <td>±.005</td> <td>±1/4°</td> </tr> </table> <p>APPROVALS</p> <table border="1" style="width: 100%; border-collapse: collapse;"> <tr> <th>APPROVALS</th> <th>DATE</th> </tr> <tr> <td>DESIGN: T ELLERBY</td> <td>12/10/04</td> </tr> <tr> <td>CHECK: F STUMPAGES</td> <td>2/1/05</td> </tr> </table> <p>DATE CODE: B 64818</p> <p>DWG NO.: 004655</p> <p>REV: A</p> <p>SCALE: NONE</p> <p>SHEET: 1 OF 1</p>	DECIMALS	ANGULAR	±.01	±1/2°	±.005	±1/4°	APPROVALS	DATE	DESIGN: T ELLERBY	12/10/04	CHECK: F STUMPAGES	2/1/05	<p>CONTRACT NO. _____</p> <p>TITLE: FLOW TRANSMITTER, ST75, COMPRESSION FITTING TEE, LOCAL TYPE 4X ENCLOSURE</p> <p>CONTRACT: _____</p> <p>DATE: 3/18/05</p> <p>CHKD: N PETERS</p> <p>DATE: 5/3/05</p> <p>ENGR: E WIBLE</p> <p>DATE: 2/22/05</p>
DECIMALS	ANGULAR												
±.01	±1/2°												
±.005	±1/4°												
APPROVALS	DATE												
DESIGN: T ELLERBY	12/10/04												
CHECK: F STUMPAGES	2/1/05												

4
3
2
1

NOTICE OF PROPRIETARY RIGHTS

This document contains confidential technical data, including trade secrets and proprietary information which are the property of Fluid Components Intl (FCI). Disclosure of this data to you is expressly conditioned upon your assent that its use is limited to use within your company only (and does not include manufacture or processing uses). Any other use is strictly prohibited without the prior written consent of FCI.

REVISIONS		
REV	DESCRIPTION	DATE
A	MAJOR (SEE DCN)	9/9/08

CONFIG	DIM A PIPE SIZE	DIM B TOP TO FLOW CL	DIM C FLOW CL TO BOTTOM	DIM D TEE LENGTH
ST75-XXXAXX	1/4 INCH PIPE	6.0 MAX [152.4]	.38 [9.65]	1.54 [39.12]
ST75-XXXBXX	1/2 INCH PIPE	6.3 MAX [160.1]	.35 [8.89]	2.29 [58.17]
ST75-XXXCXX	3/4 INCH PIPE	7.0 MAX [177.8]	.68 [17.27]	2.56 [65.02]
ST75-XXXDXX	1 INCH PIPE	7.3 MAX [185.4]	.65 [16.51]	2.92 [74.17]
ST75-XXXEXX	1 1/2 INCH PIPE	7.8 MAX [198.1]	1.17 [29.72]	3.82 [97.03]
ST75-XXXFXX	2 INCH PIPE	8.0 MAX [203.2]	1.42 [36.07]	4.66 [118.40]

PIPE TEE CONFIGURATION

SPECIFICATIONS:

CUSTOMER: _____

PURCHASE ORDER NO.: _____

CUSTOMER ORDER NO.: _____

WETTED SURFACE MATERIAL: _____

U LENGTH: _____

SERIAL NO.(S): _____

TAG NO.(S): _____

6. PROCESS PRESSURE: 240 PSIG MAX.

5. SEE INSTRUMENT MANUAL FOR ADDITIONAL INFORMATION AND INSTRUCTION.

4. ALL ORIENTATION AND/OR MOUNTING REFERENCES ARE INDICATED FROM TERMINAL ENCLOSURE END OF SENSING ELEMENT.

3. FOR ELECTRICAL OPTIONS, CONNECTIONS AND TESTS, SEE APPLICABLE WIRING DIAGRAM.

2. DIMENSIONS IN BRACKETS [] ARE IN MILLIMETERS.

1. THIS DRAWING IS A REFERENCE DOCUMENT ONLY.

OUTLINE/INSTALLATION DRAWING

<p>UNLESS OTHERWISE SPECIFIED DIMENSIONS ARE IN INCHES TOLERANCES</p> <table border="1" style="width: 100%; border-collapse: collapse;"> <tr> <th>DECIMALS</th> <th>ANGULAR</th> </tr> <tr> <td>±.01</td> <td>±1/2°</td> </tr> <tr> <td>±.005</td> <td>±1/4°</td> </tr> </table> <p>APPROVALS</p> <table border="1" style="width: 100%; border-collapse: collapse;"> <tr> <th>APPROVALS</th> <th>DATE</th> </tr> <tr> <td>DESIGN: T ELLERBY</td> <td>12/10/04</td> </tr> <tr> <td>CHECK: F STUMPAGES</td> <td>2/1/05</td> </tr> </table> <p>DATE CODE: B 64818</p> <p>DWG NO.: 004653</p> <p>REV: A</p> <p>SCALE: NONE</p> <p>SHEET: 1 OF 1</p>	DECIMALS	ANGULAR	±.01	±1/2°	±.005	±1/4°	APPROVALS	DATE	DESIGN: T ELLERBY	12/10/04	CHECK: F STUMPAGES	2/1/05	<p>CONTRACT NO. _____</p> <p>TITLE: FLOW TRANSMITTER, ST75, FEMALE NPT TEE, LOCAL TYPE 4X ENCLOSURE</p> <p>CONTRACT: _____</p> <p>DATE: 3/18/05</p> <p>CHKD: N PETERS</p> <p>DATE: 5/3/05</p> <p>ENGR: E WIBLE</p> <p>DATE: 2/22/05</p>
DECIMALS	ANGULAR												
±.01	±1/2°												
±.005	±1/4°												
APPROVALS	DATE												
DESIGN: T ELLERBY	12/10/04												
CHECK: F STUMPAGES	2/1/05												

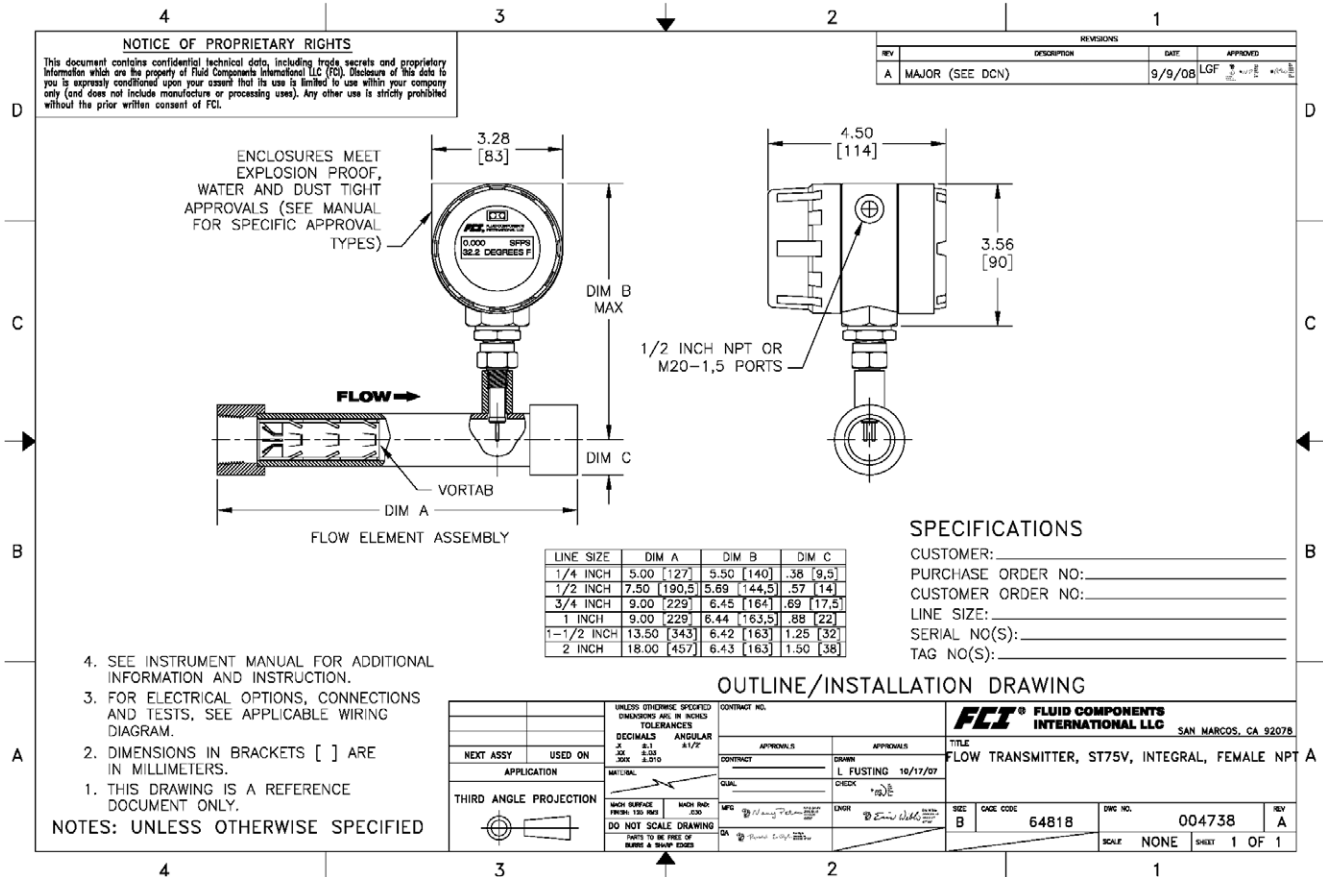
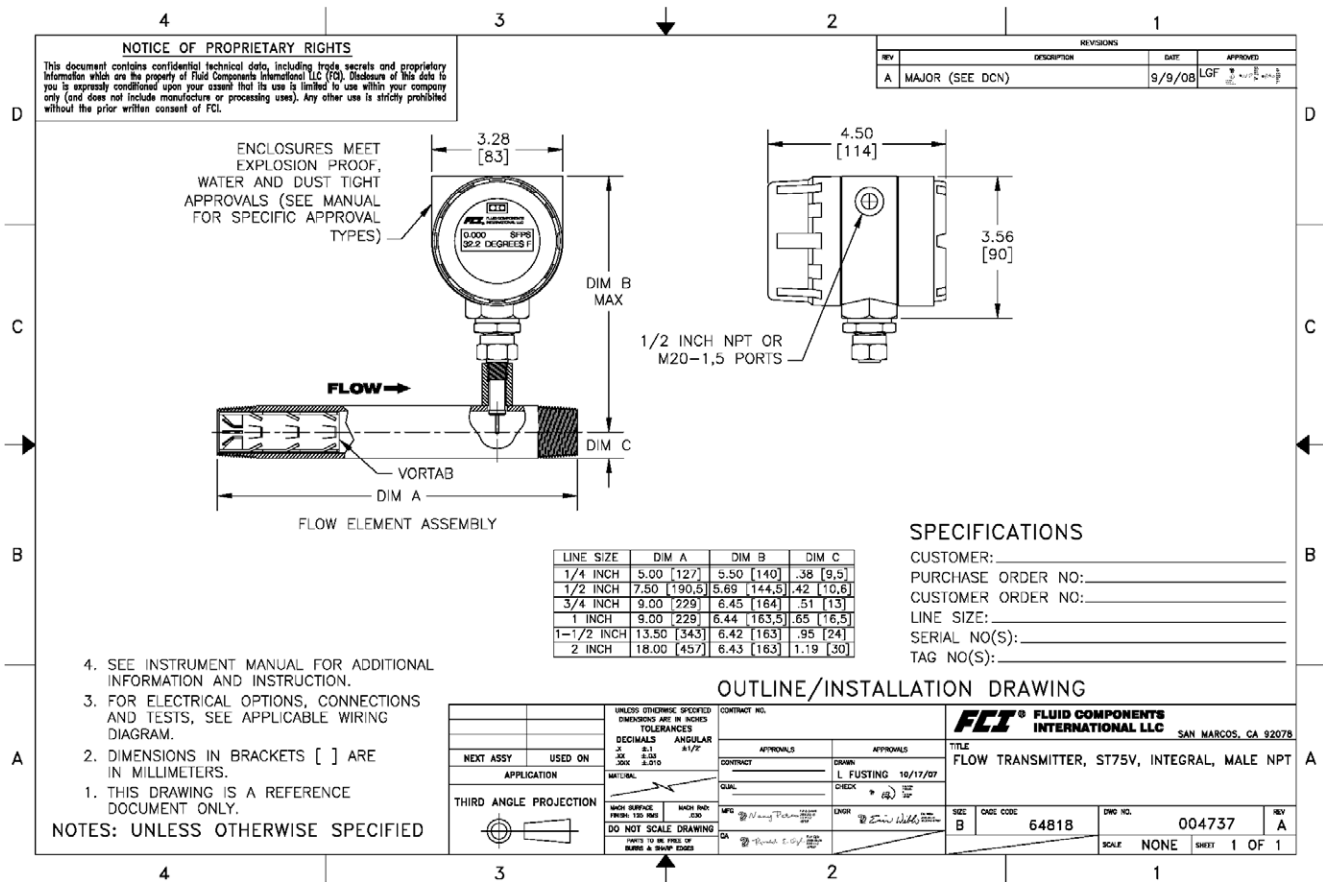

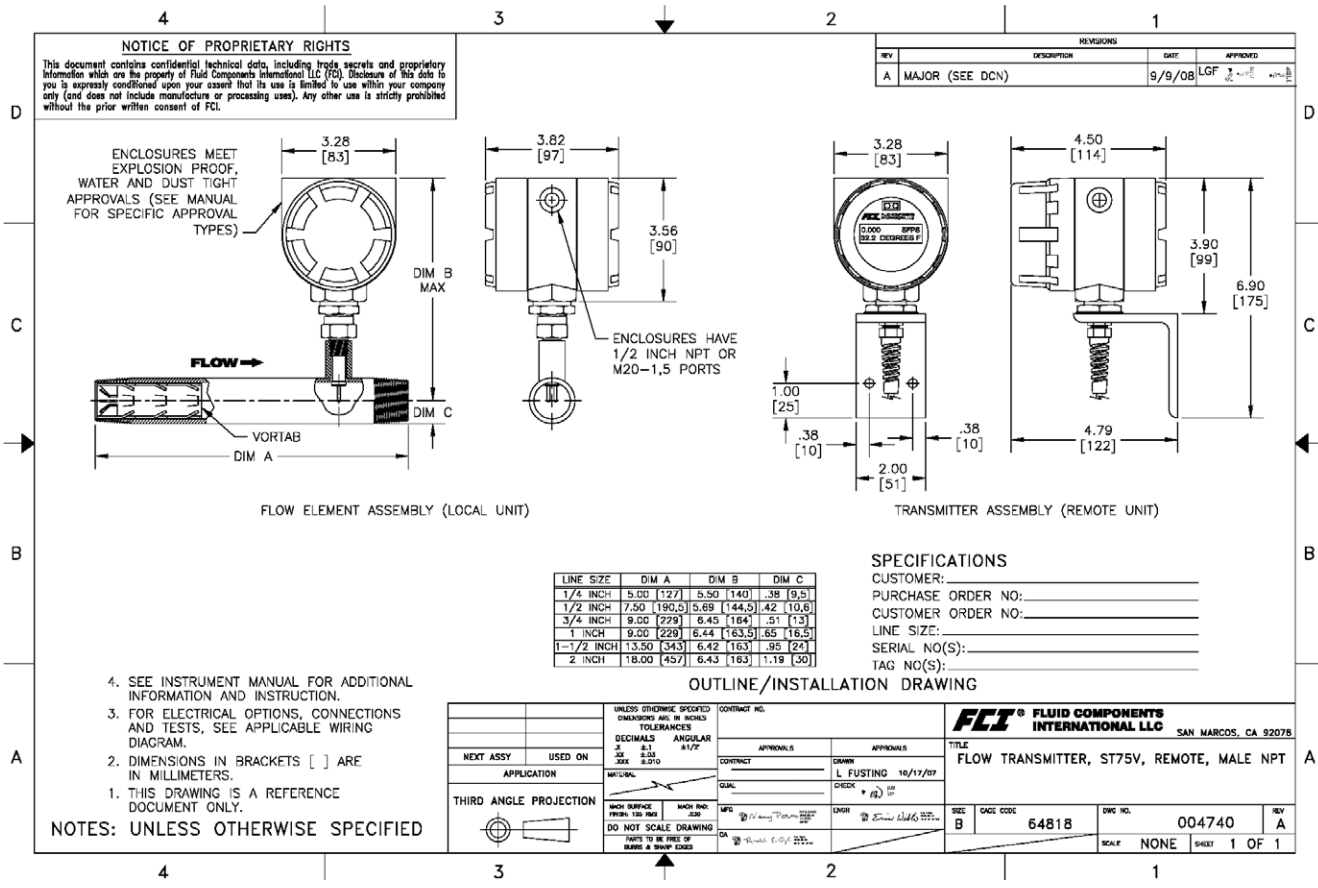
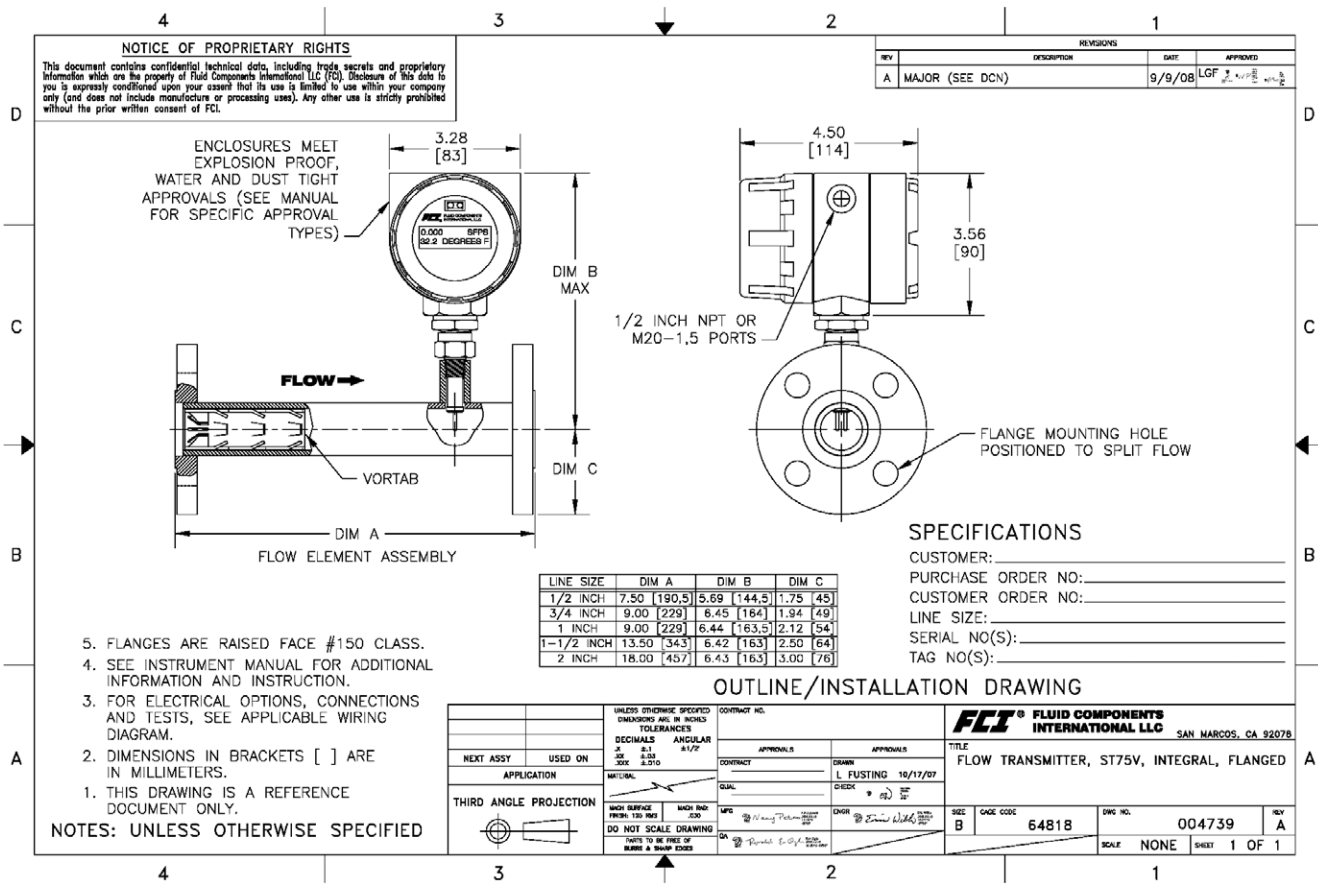

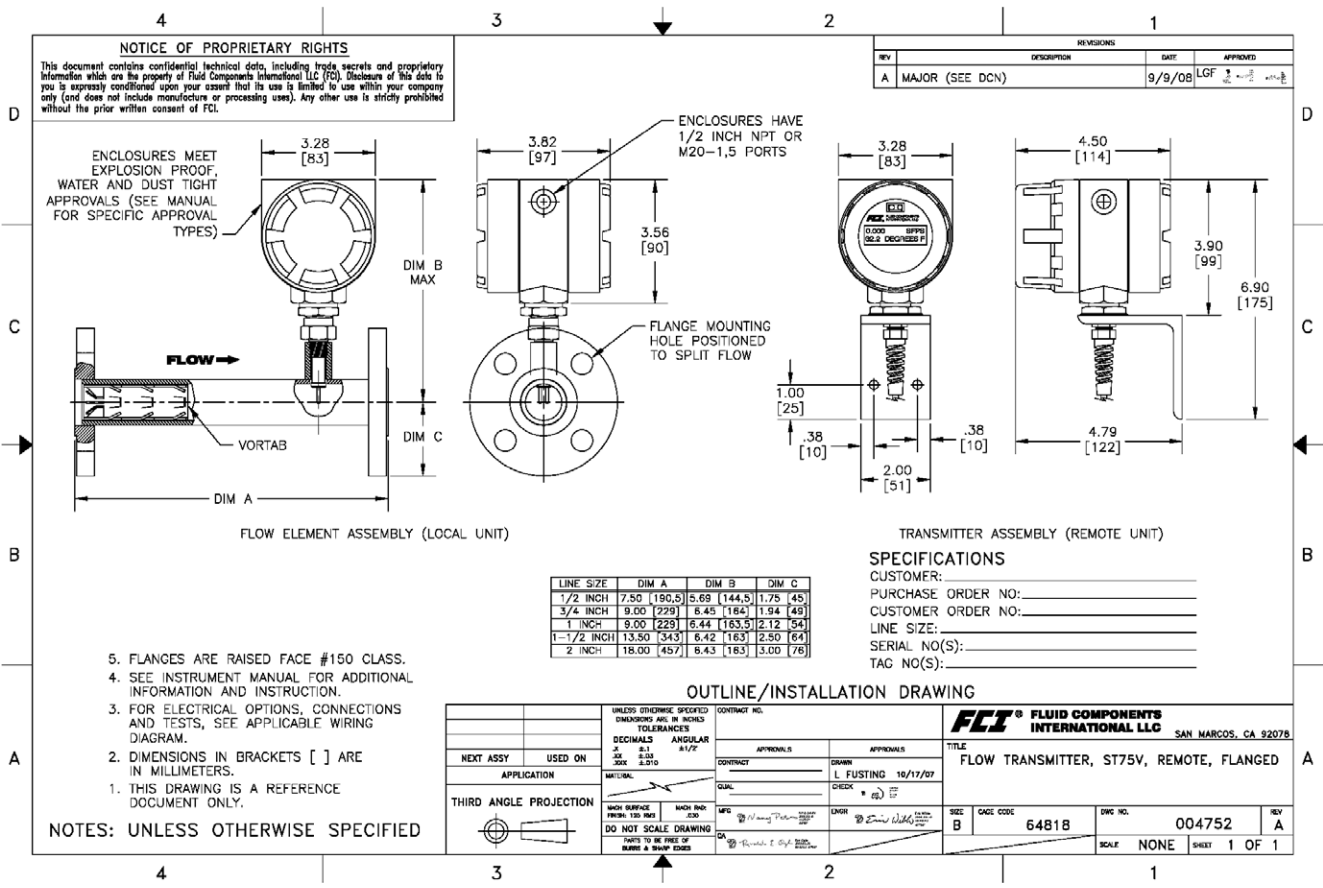
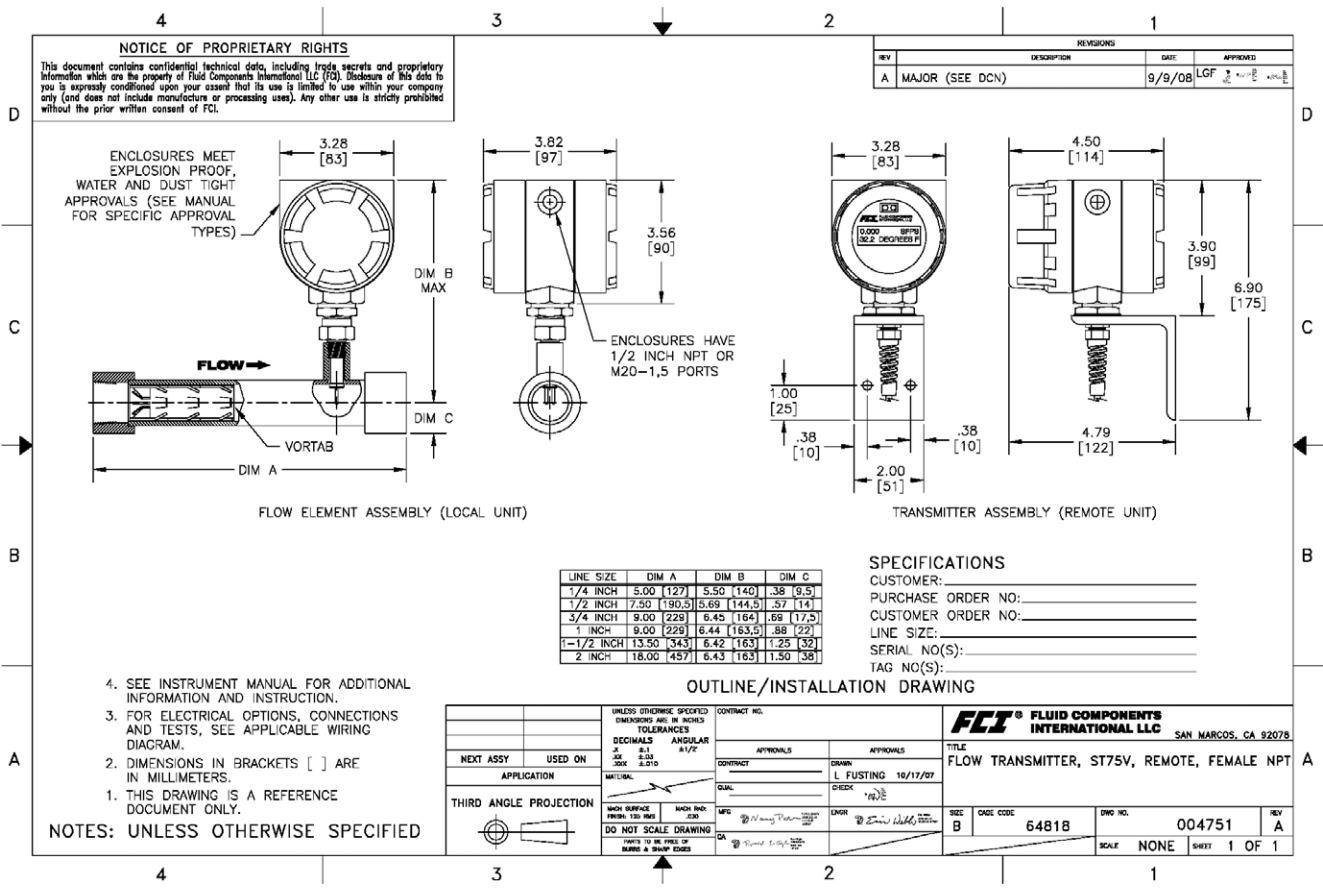

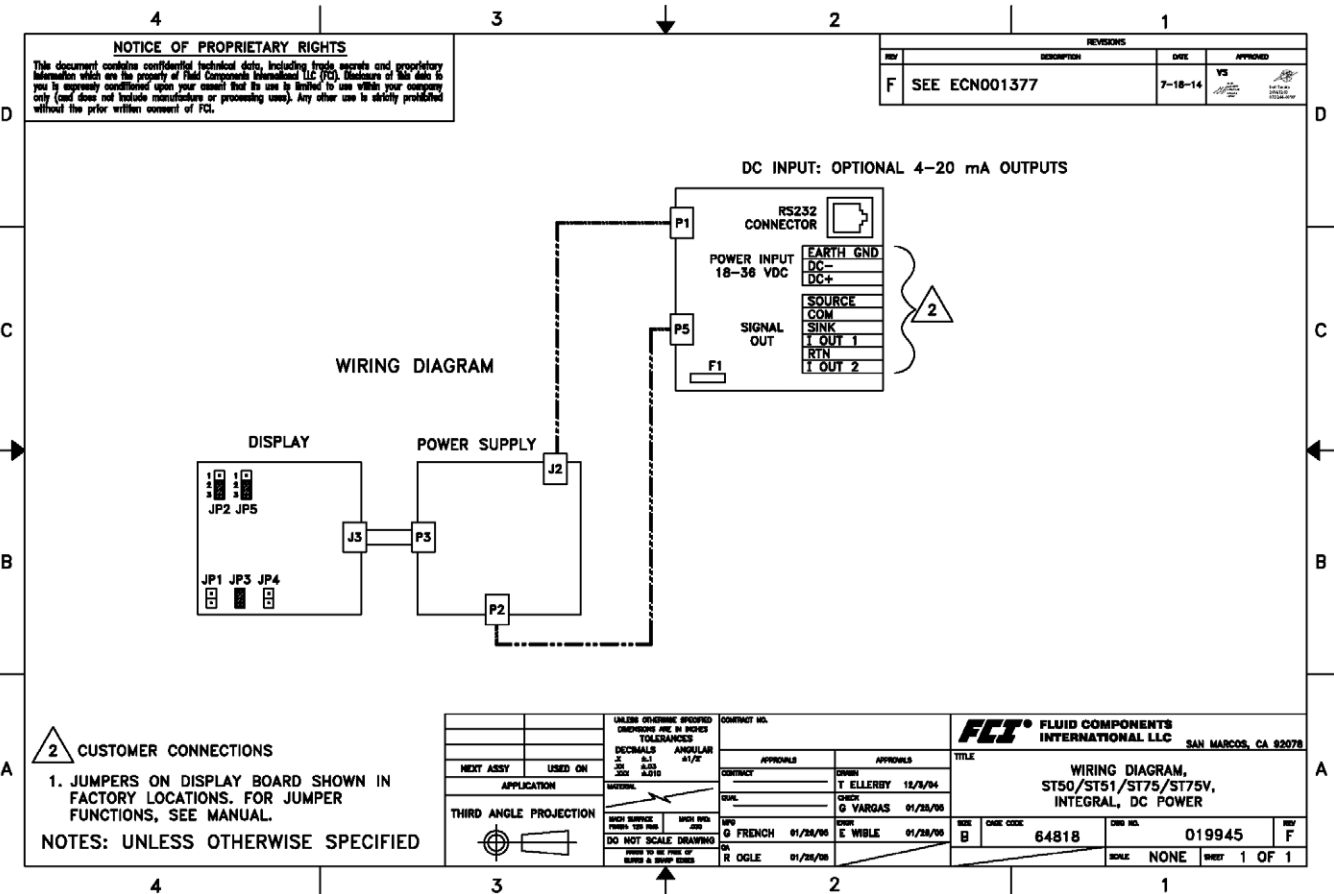
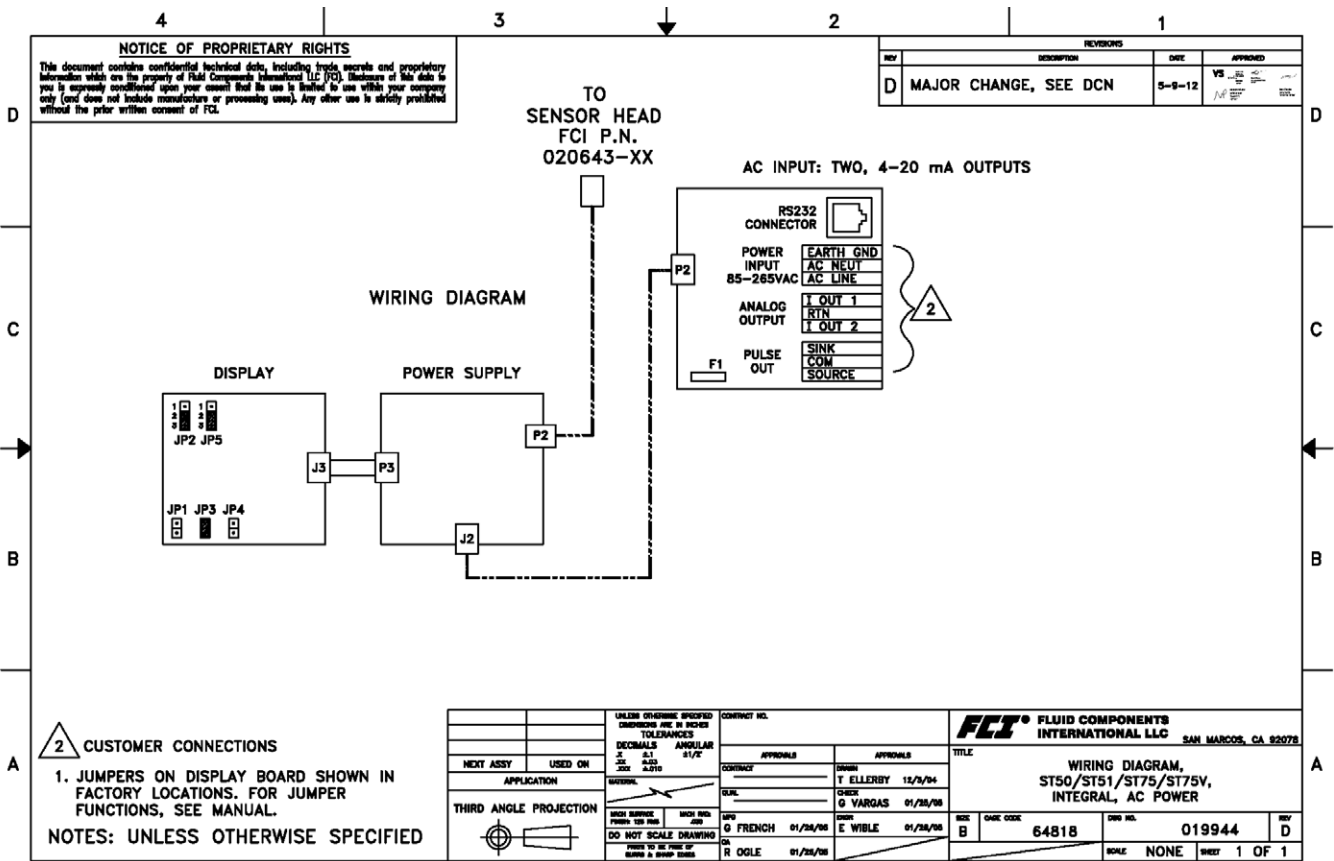

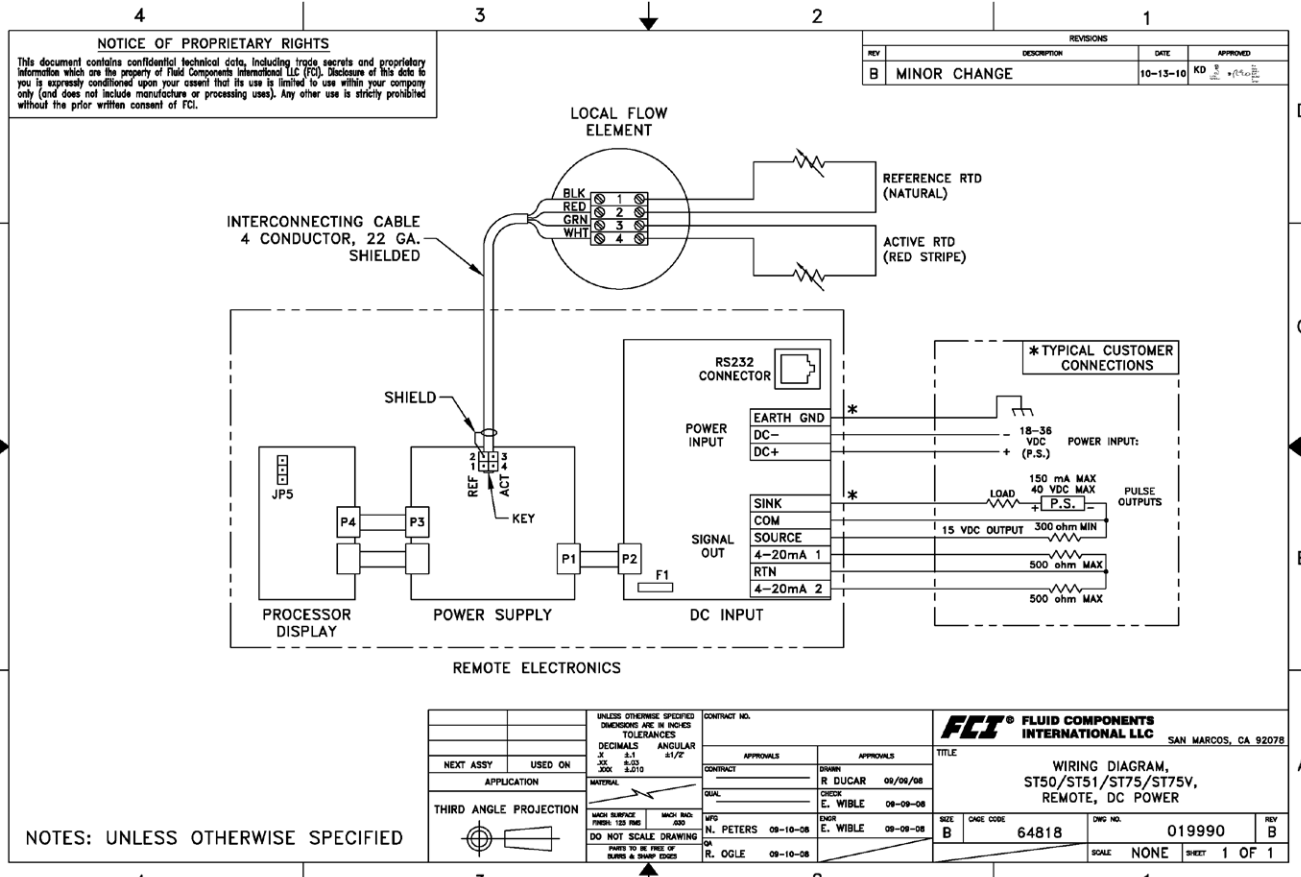
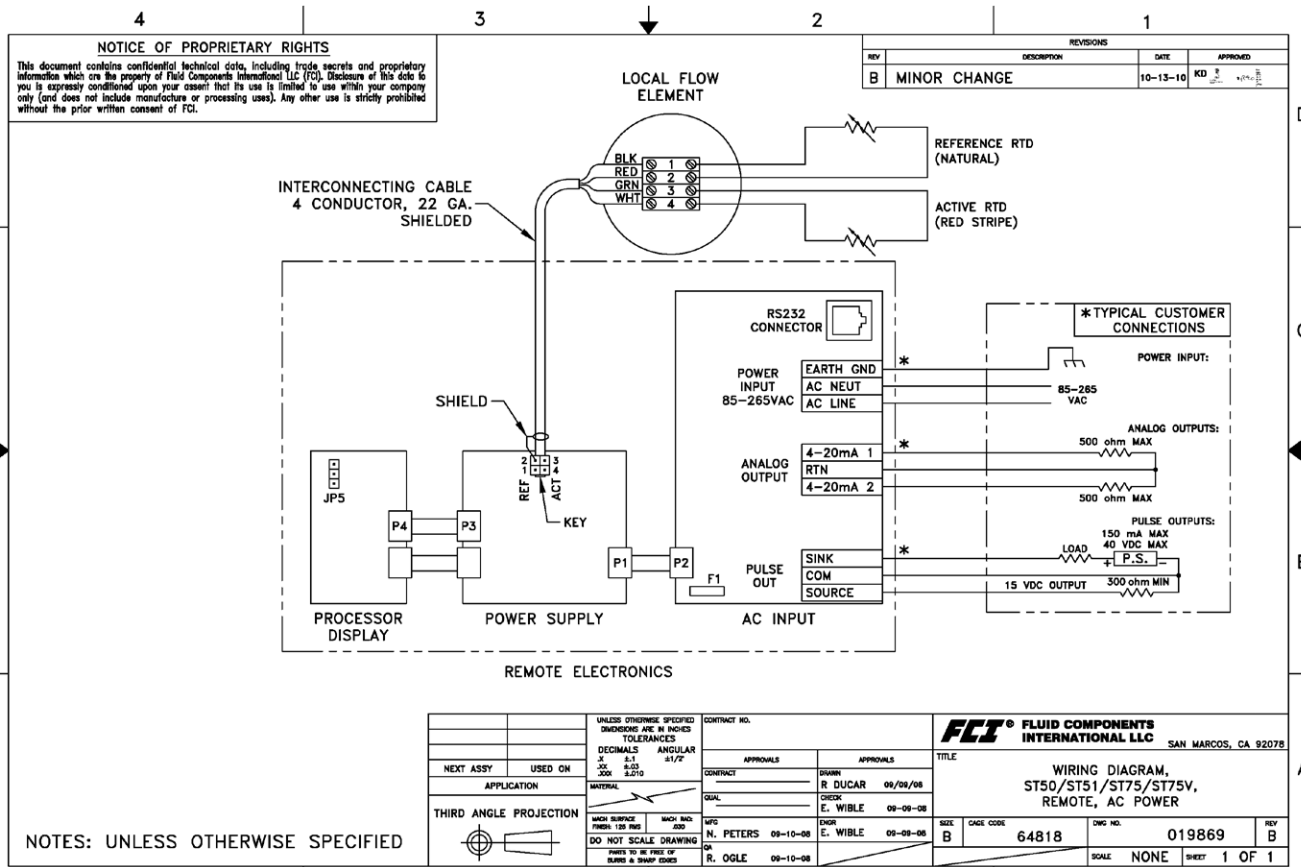

Appendix D - Customer Service

Customer Service/ Technical Support

FCI provides full in-house technical support. Additional technical representation is also provided by FCI field representatives. Before contacting a field or in-house representative, perform the troubleshooting techniques outlined in this document.

By Mail

Fluid Components International LLC
1755 La Costa Meadows Dr.
San Marcos, CA 92078-5115 USA
Attn: Customer Service Department

By Phone

Contact the area FCI regional representative. If a field representative is unable to be contacted or if a situation is unable to be resolved, contact the FCI Customer Service Department toll free at 1 (800) 854-1993.

By Fax

To describe problems in a graphical or pictorial manner, send a fax including a phone or fax number to the regional representative. Again, FCI is available by facsimile if all possibilities have been exhausted with the authorized factory representative. Our fax number is 1 (760) 736-6250; it is available 7 days a week, 24 hours a day.

By Email

FCI Customer Service can be contacted by email at: techsupport@fluidcomponents.com.

Describe the problem in detail making sure a telephone number and best time to be contacted is stated in the email.

International Support

For product information or product support outside the contiguous United States, Alaska, or Hawaii, contact your country's FCI International Representative or the one nearest to you.

After Hours Support

For product information visit the FCI website at www.fluidcomponents.com. For product support call 1 (800) 854-1993 and follow the prerecorded instructions.

Point of Contact

The point of contact for service, or return of equipment to FCI is your authorized FCI sales/service office. To locate the office nearest you, visit the FCI website at www.fluidcomponents.com.

Warranty Repairs or Returns

FCI prepays ground transportation charges for return of freight to the customer's door. FCI reserves the right to return equipment by the carrier of our choice.

International freight, handling charges, duty/entry fees for return of equipment are paid by the customer.

Non-Warranty Repairs or Returns

FCI returns repaired equipment to the customer either collect or prepaid and adds freight charges to the customer invoice.

Return to Stock Equipment

The customer is responsible for all shipping and freight charges for equipment that is returned to FCI stock from the customer site. These items will not be credited to customer's account until either all freight charges are cleared or until the customer agrees to have any freight costs incurred by FCI deducted, along with applicable return to stock charges, from the credit invoice. (Exceptions are made for duplicate shipments made by FCI.)

If any repair or return equipment is received at FCI, freight collect, without prior factory consent, FCI bills the sender for these charges.

Field Service Procedures

Contact an FCI field representative to request field service.

A field service technician is dispatched to the site from either the FCI factory or one of the FCI representative offices. After the work is complete, the technician completes a preliminary field service report at the customer site and leaves a copy with the customer.

Following the service call, the technician completes a formal, detailed service report. The formal report is mailed to the customer within five days of the technician's return to the factory or office.

Field Service Rates

All field service calls are billed at the prevailing rates as listed in the FCI Price Book unless specifically excepted by the FCI Customer Service Manager. FCI reserves the right to bill for travel times at FCI's discretion.

Customers are charged for shipping costs related to the transfer of equipment to and from the job site. They are also invoiced for field service work and travel expenses by FCI's Accounting Department.



1755 La Costa Meadows Drive, San Marcos, CA 92078-5115 USA
760-744-6950 / 800-854-1993 / Fax: 760-736-6250
Web Site: www.fluidcomponents.com
E-mail: techsupport@fluidcomponents.com

RA # _____

Return Authorization Request

1. Return Customer Information

Returning Company's Name: _____ Phone# _____
Return Contact Name: _____ Fax # _____
Email Address: _____

2. Return Address

Bill To: _____ Ship To: _____

3. Mandatory End User Information

Contact: _____ Company: _____ Country: _____

4. Return Product Information

Model No: _____ Serial No(s): _____
Failure Symptoms (Detailed Description Required): _____

What Trouble Shooting Was Done Via Phone or Field Visit by FCI: _____

FCI Factory Technical Service Contact: _____

- 5. Reason For Return** Sensor Element Electronics As Found Testing Credit
 Recalibrate (New Data) Recalibrate (Most Recent Data) Other

(Note: A new Application Data Sheet (ADS) must be submitted for all recalibrations and re-certifications)

- 6. Payment Via** Faxed Purchase Order  

(Note: A priced quotation is provided for all Non-Warranty repairs after equipment has been evaluated. All Non-Warranty repairs are subject to a minimum evaluation charge of \$250.00)

Factory Return Shipping Address: Fluid Components International LLC
1755 La Costa Meadows Drive
San Marcos, CA 92078-5115
Attn: Repair Department
RA # _____



The following Return Authorization Request form and Decontamination Statement **MUST be completed, signed and faxed back to FCI before** a Return Authorization Number will be issued. The signed Decontamination Statement and applicable MSDS Sheets **must be included with the shipment**. FCI will fax, email or telephone you with the Return Authorization Number upon receipt of the signed forms.

Packing Procedures

1. **Electronics** should be wrapped in an **anti-static** or **static-resistant** bag, then wrapped in protective bubble wrap and surrounded with appropriate dunnage* in a box. Instruments weighing **more than 50 lbs., or extending more than four feet**, should be secured in wooden crates by bolting the assemblies in place.
2. The sensor head must be protected with pvc tubing, or retracted the full length of the probe, locked and secured into the Packing Gland Assembly (cap screws tightened down).
3. FCI can supply crates for a nominal fee.
4. No more than four (4) small units packaged in each carton.
5. FCI will not be held liable for damage caused during shipping.
6. To ensure immediate processing mark the RA number on the outside of the box. Items without an RA number marked on the box or crate may be delayed.
7. Freight must be "PrePaid" to FCI receiving door.

* Appropriate dunnage as defined by UPS, will protect package contents from a drop of 3 feet.

***** Decontamination Statement *** This Section Must Be Completed *****

Exposure to hazardous materials is regulated by Federal, State, County and City laws and regulations. These laws provide FCI's employees with the "Right to Know" the hazardous or toxic materials or substances in which they may come in contact while handling returned products. Consequently, FCI's employees must have access to data regarding the hazardous or toxic materials or substances the equipment has been exposed to while in a customer's possession. Prior to returning the instrument for evaluation/repair, FCI requires thorough compliance with these instructions. The signer of the Certificate must be either a knowledgeable Engineer, Safety Manager, Industrial Hygienist or of similar knowledge or training and responsible for the safe handling of the material to which the unit has been exposed. **Returns without a legitimate Certification of Decontamination, and/or MSDS when required, are unacceptable and shall be returned at the customer's expense and risk.** Properly executed Certifications of Decontamination must be provided before a repair authorization (RA) number will be issued.

Certification Of Decontamination

I certify that the returned item(s) has(have) been thoroughly and completely cleaned. If the returned item(s) has(have) been exposed to hazardous or toxic materials or substances, even though it (they) has (have) been thoroughly cleaned and decontaminated, the undersigned attests that the attached Material Data Safety Sheet(s) (MSDS) covers said materials or substances completely. Furthermore, I understand that this Certificate, and providing the MSDS, shall not waive our responsibility to provide a neutralized, decontaminated, and clean product for evaluation/repair at FCI. Cleanliness of a returned item or acceptability of the MSDS shall be at the sole discretion of FCI. **Any item returned which does not comply with this certification shall be returned to your location Freight Collect and at your risk.**

This certification must be signed by knowledgeable personnel responsible for maintaining or managing the safety program at your facility.

Process Flow Media _____

Product was or may have been exposed to the following substances: _____

Print Name _____

Authorized Signature _____ Date _____

Company Title _____

Visit FCI on the Worldwide Web: www.fluidcomponents.com

1755 La Costa Meadows Drive, San Marcos, California 92078-5115 USA ‡ Phone: 760-744-6950 ‡ 800-854-1993 ‡ Fax: 760-736-6250

FCI Document No. 05CS000004D [U]

Instrument Warranty

Goods furnished by the Seller are to be within the limits and of the sizes published by the Seller and subject to the Seller's standard tolerances for variations. All items made by the Seller are inspected before shipment, and should any of said items prove defective due to faults in manufacture or performance under Seller approved applications, or fail to meet the written specifications accepted by the Seller, they will be replaced or repaired by Seller at no charge to Buyer provided return or notice of rejection of such material is made within a reasonable period but in no event longer than one (1) year from date of shipment to Buyer, and provided further, that an examination by Seller discloses to Seller's reasonable satisfaction that the defect is covered by this warranty and that the Buyer has not returned the equipment in a damaged condition due to Buyer's or Buyer's employees', agents', or representatives' negligence and Buyer has not tampered, modified, redesigned, misapplied, abused, or misused the goods as to cause the goods to fail. In addition, this warranty shall not cover damage caused by Buyer's exposure of the goods to corrosive or abrasive environments. Moreover, Seller shall in no event be responsible for (1) the cost or repair of any work done by Buyer on material furnished hereunder (unless specifically authorized in writing in each instance by Seller), (2) the cost or repair of any modifications added by a Distributor or a third party, (3) any consequential or incidental damages, losses, or expenses in connection with or by reason of the use of or inability to use goods purchased for any purpose, and Seller's liability shall be specifically limited to free replacement, or refund of the purchase price, at Seller's option, provided return or rejection of the goods is made consistent with this paragraph, and the Seller shall in no event be liable for transportation, installation, adjustment, loss of good will or profits, or other expenses which may arise in connection with such returned goods, or (4) the design of products or their suitability for the purpose for which they are intended or used. Should the Buyer receive defective goods as defined by this paragraph, the Buyer shall notify the Seller immediately, stating full particulars in support of his claim, and should the Seller agree to a return of the goods, the Buyer shall follow Seller's packaging and transportation directions explicitly. In no case are the goods to be returned without first obtaining a return authorization from the Seller. Any repair or replacement shall be at Seller's factory, unless otherwise directed, and shall be returned to Seller transportation prepaid by Buyer. If the returned goods shall prove defective under this clause they will be replaced or repaired by Seller at no charge to Buyer provided the return or rejection of such material is made within a reasonable period, but in no event longer than (1) year from the date of shipment of the returned goods or the unexpired terms of the original warranty period whichever is later. If the goods prove to be defective under this paragraph, the Buyer shall remove the goods immediately from the process and prepare the goods for shipment to Seller. Continued use or operation of defective goods is not warranted by Seller and damage occurring due to continued use or operation shall be for Buyer's account. Any description of the goods contained in this offer is for the sole purpose of identifying them, and any such description is not part of the basis of the bargain, and does not constitute a warranty that the goods will conform to that description. The use of any sample or model in connection with this offer is for illustrative purposes only, is not part of the basis of the bargain, and is not to be construed as a warranty that the goods will conform to the sample or model. No affirmation of that fact or promise made by the Seller, whether or not in this offer, will constitute a warranty that the goods will conform to the affirmation or promise. THIS WARRANTY IS EXPRESSLY IN LIEU OF ANY AND ALL OTHER EXPRESS OR IMPLIED WARRANTIES WITH RESPECT TO THE GOODS OR THEIR INSTALLATION, USE, OPERATION, REPLACEMENT OR REPAIR, INCLUDING ANY IMPLIED WARRANTY OF MERCHANTABILITY OR FITNESS OF PURPOSE; AND THE GOODS ARE BEING PURCHASED BY BUYER "AS IS". SELLER WILL NOT BE LIABLE BY VIRTUE OF THIS WARRANTY OR OTHERWISE FOR ANY SPECIAL, INCIDENTAL OR CONSEQUENTIAL LOSS OR DAMAGE RESULTING FROM THE USE OR LOSS OF USE OF THE GOODS.



*Flow & Level Instrumentation
Solutions for Industrial Processes*

**FCI's Complete Customer Commitment. Worldwide
ISO 9001 and AS9100 Certified**

Notice of Proprietary Rights

This document is the property of Fluid Components International LLC (FCI) and contains confidential and proprietary information including, without limitation, trade secrets, design, manufacturing, processing, form fit and function data, technical data, and/or cost and pricing information, developed exclusively at FCI's private expense. Disclosure of this information to you is expressly conditioned on your assent that its use is limited to use only within your company (and does not include manufacturing or processing uses). Any other use, including re-procurement, replication of FCI products, or other use directly or indirectly in any way detrimental to FCI's interests is strictly prohibited without prior written consent of FCI. This document is subject to the protections of 18USC1905 (Trade Secrets Act), 5USC552 (Freedom of Information Act), Executive Order 12600 of 6/23/87, 18USC1832 (Economic Espionage and Trade Secrets Act of 1996), and Cal. Civ. Code 3426 et seq (Uniform California Trade Secrets Act). Recipients of this document agree to maintain this legend and affix it to any duplication or reproduction, in whole or in part, of the document.

Visit FCI online: www.fluidcomponents.com
1755 La Costa Meadows Drive, San Marcos, California 92078 USA – 760-744-6950 – 800-854-1993 – Fax 760-736-6250