

# FLOW Control

The Magazine of Fluid Handling Technology

## Emphasis on CONTROL COMPONENTS



- Valves
- Pumps
- Regulators
- Membranes
- Transmitter
- Accessories

**PLUS**  
CONTAINMENT COMPONENTS

MEASUREMENT COMPONENTS

## Thermal Dispersion

Thermal dispersion flow sensing technology has expanded beyond its original oil and gas industry applications to see use in diverse industries, including process control, aerospace, pollution monitoring and more. The latest advances in this technology are now increasing its range of fluid handling capabilities with new sensor designs, state-of-the-art electronics, advanced manufacturing techniques and sophisticated calibration facilities.

Many of these recent advances are improving the price-performance attractiveness of thermal dispersion technology. Once considered only for high reliability applications, thermal dispersion flow sensing is now a good fit in many basic applications, such as air and water measurement.

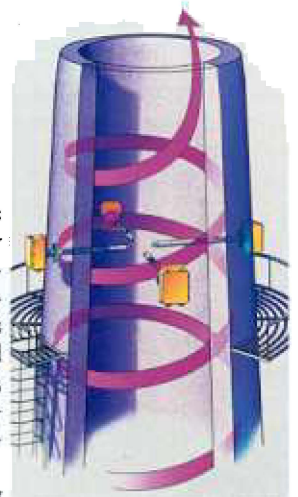

## Custom Engineering

Custom engineering assistance can provide fluid control users with simplified processes and higher quality products.

When it comes to custom design engineering, there are basically two types of customization: hardware redesign and software program development. Hardware redesign affords the user the advantage of a lower cost of hardware engineering. The main advantage of software program development is that it allows the user to avoid hardware engineering costs altogether.

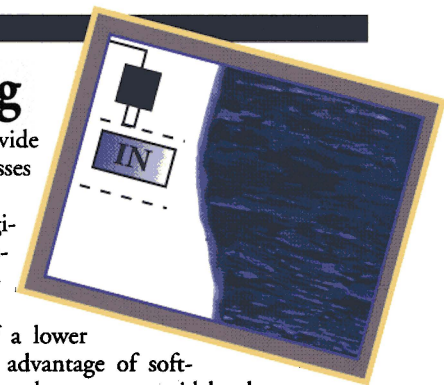

## Double Containment Piping

The detailed piping design must recognize and address several special design requirements for double containment or risk unpalatable environmental and economic costs. The main purpose of a double contained piping system and associated leak detection is to prevent an environmental release. A related purpose is to limit the cost and disruption of handling leaks when they occur. Leaks are almost inevitable in the life of any system, which is why double containment systems were developed.

Bulk Rate  
U.S. Postage  
PAID  
Shepherdsville, KY  
Permit No. 135



# Versatile Thermal Dispersion Flow Sensing Technology:

Thermal dispersion is one of several flow sensing technologies that also include coriolis, differential pressure, turbine and vortex shedding. First applied over 30 years ago in the oil/gas industry, thermal dispersion flow sensing technology has since expanded to diverse industries, including process control, aerospace, pollution monitoring and more. The latest advances in this technology are now increasing its range of fluid handling capabilities with new sensor designs, state-of-the-art electronics, advanced manufacturing techniques and sophisticated calibration facilities.

Many of these recent advances are improving the price-performance attractiveness of thermal dispersion technology. Once considered only for high reliability applications, thermal dispersion flow sensing is now a good fit in many basic applications, such as air and water measurement. At the same time, thermal dispersion technology also is still improving in high performance flow applications with conditioners that now perform fluid straightening and mixing.

## OPERATING PRINCIPLE

All thermal dispersion flow devices are based on a single concept: flow is measured by its cooling effect on a heated sensor element exposed to a flowing medium.

The heat transfer equation is:

$$P_v = K (Q/T)^{1.7}$$

P = fluid density

v = fluid velocity

K = meter factor or calibration constant

Q = heat flow rate from the cylinder to the fluid

T = heated cylinder temperature minus process fluid temperature

The principles behind one type of thermal dispersion technology are illustrated in Figure 1. The heated object is a metal cylinder called a thermowell. A precise resistive heating element inside produces a constant wattage.

Thermal sensors respond to the mass velocity of a gas. Mass velocity is the product of actual velocity (ft/s) and density (lb/ft<sup>3</sup>). Thermal flowmeters are for this reason considered to be point-sensing mass flowmeters.

Two resistive temperature devices (RTDs) sense the difference in temperature between the body of a heated thermowell and the medium that is flowing. The RTDs are called the active and the reference RTDs and are mounted in a thermowell that is the same size and shape as the heater thermowell.

The active and heater thermowells are brazed or welded together for heat transfer. The reference sensor is thermally isolated by a physical separation and is provided with additional mass so both RTDs respond at an equal rate of change to flowing media temperature variations.

The flow rate is inversely proportional to the temperature difference between the two RTDs. The logarithmic relationship, although requiring linearization for most uses, does minimize errors over large ranges of measurement.

Increases in the flow rate result in a decrease in the temperature difference. There is an empirical relationship for any given gas within a given range of temperature, which is digitally processed in the flowmeter as an output signal.

The mass flow rate is determined simply by multiplying the mass velocity by the

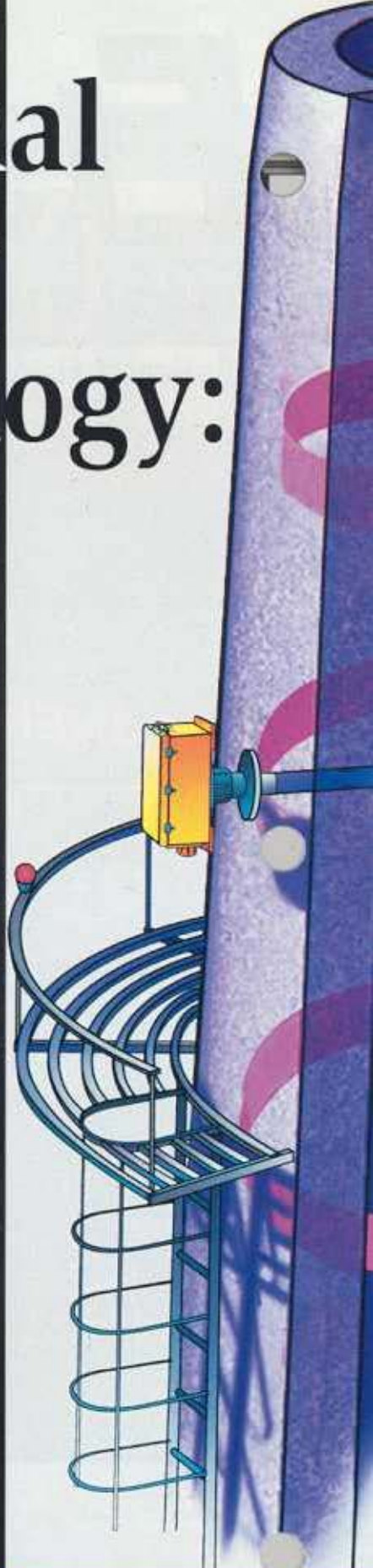

By Eric Wible



# From The Basics To Advanced Applications

cross-sectional area of the passage. A factor is applied to the result to correct for a nonuniform flow profile across the extent of the passage.

Thermal dispersion flow sensing technology offers a variety of inherent advantages over other types of flowmeters, such as coriolis, differential-pressure, turbine and vortex shedding. Their primary advantage is accuracy over flow ranges of 100 to 1 (wide turndown), low flow sensitivity, direct mass-flow measurement, reliability and long-life. Accuracy is specified at 1 percent of reading, and repeatability is as good as 0.1 percent of full scale.

## SMARTER ELECTRONICS AND NEW MATERIALS

Today's microprocessor based thermal flowmeters eliminate the difficulty and possibility of error often encountered when programming with handheld terminals, meters and calibrator units. Figure 2 is a block diagram showing a microprocessor-based air thermal flowmeter. The software is stored in a 32KB ROM chip. A smaller nonvolatile RAM chip contains the working memory and user configuration data.

Programmed routines use the stored numbers to make calculations and decisions required for the instrument's various functions. The heater current, for example, is squared and multiplied by the heater voltage and yields the heater wattage, from which the desired constant value is subtracted to generate an error signal to the heater current circuit.

The microprocessor feeds a D/A converter to produce four different analog outputs. Two outputs are summed to produce a 16-bit output mass flow rate signal. The other outputs are used to control the constant current circuits — one for sensor balance, one for heater power control. As the primary function of the meter, a current driver circuit converts the mass-flow-rate voltage signal into a 4-20 mA signal with direct feedback control by the microcontroller.

Other advances in electronics include new flexible switch technology control circuits. When combined with thermal sensors based on new Monel and Titanium alloys, the result is a next generation multi-function flow technology that is much smarter and more capable. For example, flow, level and temperature monitoring/switching technologies have been integrated into a single highly accurate thermal dispersion device that performs simultaneous monitoring/switching for temperature and flow or liquid level/interface control in gas, liquid or slurry.

The control circuit developed for integrated flow/level/temperature sensing is based on a fail-safe, dual-relay (SPDT) circuit board. Field selected configurations include dual SPDT relays that can be

set to operate simultaneously as one DPDT relay for single alarming of flow rate, liquid level or temperature and dual relays configured to alarm as independent SPDT relays to combine temperature and flow rate, flow rate and low liquid level, three-phase interface and more.

Accuracies for this type of integrated technology instrument in flow, level and temperature are: +2 percent of set point velocity, as low as +0.09 inches and +2°F, respectively. An integrated function application using this technology, for example, is a hot or cold liquid product processing operation where flow must be constantly monitored, wet/dry level detection is important to protect equipment and high/low temperature alarms are necessary to achieve product consistency.

In another application involving gas analyzer stations supporting a ventilation system at a chemical plant, integrated flow/level/temperature technology was used primarily because it combined a rugged sensor having a no-moving parts design with a flexible control switch. The reliability, multi-function performance and cost advantages, in comparison to Delta-P type and turbine-type flowmeters, were viewed as significant.

The trend toward smarter, multi-functional flow instrumentation is growing. Today's newest specialty chemical and processed food plants, for example, are more complex than those of a decade ago. The problem, however, is the competitive pressure to produce these products at ever lower prices forces manufacturers to search continuously for process simplification. It is here where the performance and evolving capabilities of thermal dispersion technology are having their greatest impact.

## FLOW SWITCH/MONITORING

While many applications for flow switch/monitoring haven't changed much, the need for lower cost devices is growing. The newest generation of these products now features a standardized set of basic capabilities at a much lower cost that allow one instrument to perform most popular applications, such as pump protection, pipeline flow/no flow detection and relief valve and flare gas flow detection.

For example, insertion-type flow switch/monitors protect pumps by monitoring product flow. Positive displacement and centrifugal pump systems can be saved from dry or low flow operating damage. Flow switch/monitors are effective in virtually all media, including slurries and viscous products. These instruments are easily incorporated into existing control circuitry to actuate pump shutoff in a low or no flow condition.

When flow switch/monitors are installed in lateral lines or down-

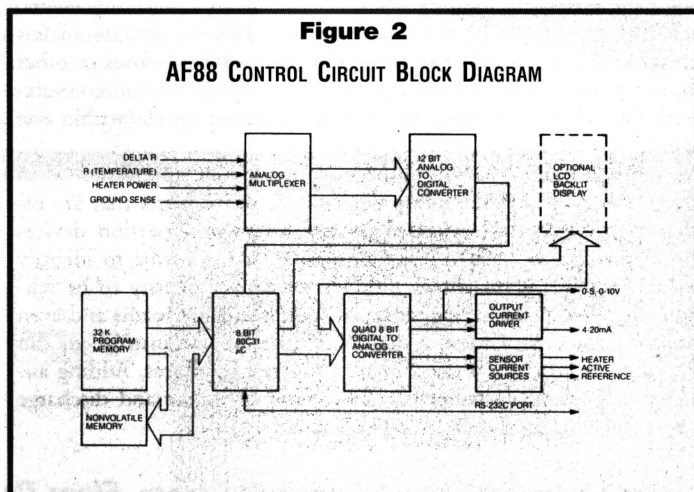
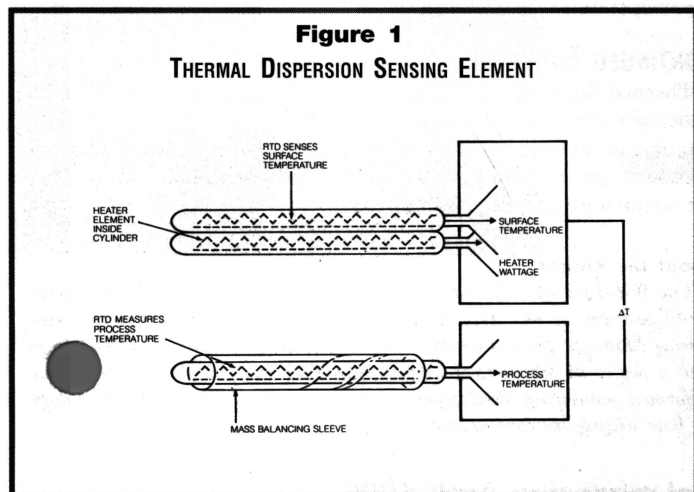

**Figure 3**  
RELIEF VALVE & FLARE GAS FLOW DETECTION

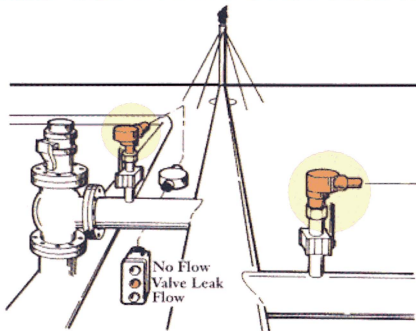

**Figure 4**  
INTERFACE CONTROL IN SEPARATION VESSELS

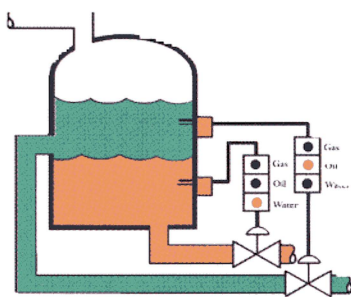

stream of relief valves feeding into a main flare header, they quickly and precisely indicate the source of flare gas (Figure 3). This allows operators to readily identify related problems within refineries or chemical plants. In waste water treatment facilities, flow switch/monitors are also used to measure gas flow from sludge digesters to flare systems and relief valves.

## LEVEL AND INTERFACE CONTROL

Thermal based liquid level and interface controllers are suitable for a wide range of applications. New basic instruments that combine the most popular features in standardized products are now capable of performing all routine applications, from wet/dry detection or high/low level alarming to complex interface control in separation vessels at an economical cost.

In wet/dry detection, a liquid level/interface controller provides excellent response-time for single-point detection in almost any media. Each instrument can be used either as an alarm to actuate an annunciator or as a controller to actuate pumps, solenoid valves or other process systems. Liquid level can be controlled to within +one-sixteenth inch of the trip point. Instrument response time is within one second.

A more complex thermal dispersion instrument application is in separation vessels. Unlike density-dependent instruments that are often used for level and interface control, thermal dispersion devices rely on the specific heat transfer properties of the media to identify product interface. This allows products of similar density to be reliably controlled in separating tanks, including slurries, foams and even emulsion layers. To achieve a dual switch point, one instrument can be configured to control two different product interfaces. Adding another two or more instruments allows product intake and discharge to be controlled at specific points (Figure 4).

**Figure 5**  
TYPICAL STACK INSTALLATION

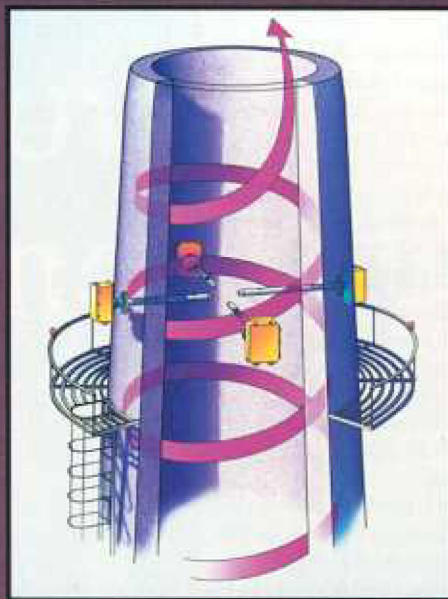

## MASS FLOW METERING

Since the relationship between flow rate and cooling effect is directly related to mass in gas applications, thermal dispersion technology combined with advanced microprocessor circuitry provides a highly repeatable and accurate measurement of gas or air mass flow rates. One of the most common applications for mass flow metering is now stack monitoring (Figure 5) as part of the Continuous Emissions Monitoring Systems (CEMS) mandated by the Clean Air Act of 1990.

In CEMS stacks, flowmeters with microprocessor-based control circuits execute continuous data sampling and signal processing to check for out-of-range input signals that may indicate a sensor problem or system problem. For air and flue gas monitoring applications in large pipes or ducts where limited straight runs result in irregular flow profiles, multipoint mass flowmeters are used with two to 16 sensor elements.

Another mass flow metering application is commonly found in boilers, furnaces and cogeneration units where combustion and pre-heater air flow is metered to ensure optimum equipment performance. The instrument is placed on both the main header and on individual feed lines. Here, the rugged construction of thermal based instruments is a distinct advantage capable of withstanding operating temperatures of up to 850°F.

## CONTINUED EVOLUTION

Thermal dispersion and other flow sensing technologies will continue to evolve with advances in electronics, sensor materials and manufacturing techniques. Flow sensing, switching and metering applications are truly limited only by the imagination of those using the technology and its supplier base. **FC**

### About the Author

Eric Wibel joined FCI (San Marcos, CA) in 1982 and has held a number of positions at FCI prior to becoming Standard Products Group Engineering Manager. He is a graduate of California State University San Diego with a degree in Mechanical Engineering. FCI was founded in 1970 and performed pioneering development work on thermal dispersion technology for flow sensing instrumentation.